



C3/AB, C3/C, C3Multi, C3/CMulti
CONVECTION MICROWAVE OVEN
SERVICE AND REPAIR MANUAL



TURBOCHEF TECHNOLOGIES INC.

www.turbochef.com

10500 Metric Drive, Suite 128, Dallas, Texas 75243 USA

(800) 908 TURBO (8-8726)

© 2004 - TurboChef Technologies Inc

PN: TC3-0215 Rev. D January 2, 2004

TurboChef Technologies, Inc.

This page intentionally left blank.

Table of Contents

READ THIS FIRST	i
Important Safety Instructions	ii
Precautions to Avoid Possible Exposure to Excessive Microwave Energy	iii
Precautions to be Observed Before and During Servicing to Avoid Possible Exposure to Excessive Microwave Energy	iv
Grounding Instructions	v
Power Cord Replacement	v
RF Interference Considerations	vi
Chapter 1 Installation Specs	
Oven Description	1-2
Installation	1-2
Oven Location	1-3
Chapter 2 Cleaning & Care	
Basic Cleaning Procedures	2-2
Chapter 3 Theory of Operation	
Theory of Operation Description	3-2
Glossary of Common Operating Terms	3-3
Programming Mode	3-4
Chapter 4 Fault Codes	
Fault Code Introduction	4-2
Fault Code Summary Matrix	4-3
Chapter 5 Test	
Test Function Detailed Description	5-2
Passwords for Operating C3 ovens	5-3
Chapter 6 Electrical Compartment & Controls	
Electrical Component Locations C3/AB	6-2
Electrical Component Locations C3/C	6-3
Electrical Component Locations C3/Multi	6-4
Electrical Component Locations C3/C Multi	6-5
Electrical Component Parts Lists	6-6
Control Panel Detail	6-8
Control System Troubleshooting	6-9
(SMT) I/O Board Troubleshooting	6-10
Chapter 7 Cook Door	
Door Switches and Circuit Breakers	7-2
Door Switch Adjustment	7-4
Door Removal and Replacement	7-10

TurboChef Technologies, Inc.

Door Removal and Replacement Left Side Parts List	7-13
Door Removal and Replacement Right Side Parts List	7-16
C3/C AND C3/CMULTI Door Assy and Parts List	7-18

Chapter 7 Cook Door

C3/AB and C3MULTI Door Assy and Parts List	7-21
--	------

Chapter 8 Convection Circuit

Catalytic Converter	8-2
Convection Element and Thermocouples	8-3
How to Turn Heaters ON & OFF	8-4
Changing Heater Operating Voltage	8-5
Heater Circuit Defective Messages	8-6
Convection (Blower) Motor Operation	8-9
How to Turn Blower On	8-9
Checking Input Voltage at Motor Controller	8-9
Blower Circuit Defective Messages	8-10
SP-200 Blower Motor Controller Fault Codes & Troubleshooting.....	8-11
Delta Blower Motor Controller Fault Codes & Trobleshooting.....	8-13
Convection Motor Parts List	8-16

Chapter 9 Microwave Circuit

Measuring for Microwave Radiation Leakage	9-2
Microwave Circuit Defective Messages.....	9-3
Magnetron & Monitor Circuits.....	9-3
Magnetron High Voltage Power Supply.....	9-5
Magnetron Testing	9-6
Magnetron Removal and Replacement	9-6
Component Testing (Diode, Capacitor, Transformer).....	9-7
Transformer Specifications	9-8
Waveguide Components Parts List	9-10

Chapter 10 (SMT)I/O BOARD & Schematics

C3/AB Schematic	10-2
C3/C Schematic	10-3
C3Multi Schematic	10-4
I/O Board Layout	10-5

READ THIS FIRST

Before working on the TurboChef Technologies, Inc. C Series oven you must first read the safety instructions on the following pages. The C3 series oven is a combination convection/microwave oven. While servicing this oven, an RF meter must be used at all times to check for microwave leakage. This RF reading must be recorded on your work invoice.

Very often poor cleaning will result in microwave leakage. Please refer to chapter 2, Cleaning & Operation, for information on the proper cleaning procedures.

Before removing the metal skin to access the electrical components in this oven, the power must be shut off and the oven unplugged. Wait at least one full minute before removing the oven skin so that the magnetron circuit can self-discharge. **FAILURE TO DO SO MAY RESULT IN DEATH OR SERIOUS INJURY.**

PLEASE NOTE: THIS MANUAL ONLY COVERS C3/AB OVENS PRODUCED BY THE BLODGETT OVEN CORPORATION, C3MULTI OVENS PRODUCED TURBOCHEF, C3/C AND C3/CMULTI OVENS PRODUCED BY TURBOCHEF TECHNOLOGIES IN CHINA.

This manual is divided into ten (10) chapters as follows:

1. INSTALLATION SPECS - This chapter includes oven specifications and the parameters for proper installation.
2. CLEANING & OPERATION - Improper cleaning can and will affect the operation of this oven. This chapter includes a brief description of the cleaning and operation procedures of the oven and the procedures to edit or change a cooking program.
3. THEORY OF OPERATION - This chapter provides a total oven overview of all major subsystems in the oven. Additionally, it provides a list of major terms and programming instructions.
4. FAULT CODES - This chapter includes information on all fault codes currently programmed in the oven to display in the event of a major malfunction.
5. TEST - This chapter details the Test Mode, which allows the technician to operate individual components or section of the C3 SERIES oven. **Using this feature will isolate most electrical troubleshooting problems.**
6. ELECTRICAL COMPARTMENT - This chapter identifies the electrical compartment components, including the smt board (computer board) and a troubleshooting guide. **Use the key to help isolate electrical troubleshooting problems.**
7. COOK DOOR - This chapter includes information on the Cook Door adjustment, assembly and troubleshooting techniques.
8. CONVECTION CIRCUIT - This chapter provided information on the convection and blower motor speed control. Removal and cleaning of the catalytic converter are also provided.
9. MICROWAVE CIRCUIT - This chapter includes information on the microwave circuit and stirrer motor.
10. I/O Board/Schematics - This chapter includes information on I/O board and schematics on ovens currently in the field (latest production is only represented)

This Service and Repair manual is set up for use by qualified technicians only. If you are unfamiliar with this oven, call TurboChef Technologies Inc.

IMPORTANT SAFETY INSTRUCTIONS

**WHEN USING ELECTRICAL APPLIANCES, THE FOLLOWING
BASIC SAFETY PRECAUTIONS SHOULD BE STRICTLY ADHERED TO:**



WARNING!!

To reduce the risk of burns, electric shock, fire, injury to persons or exposure to excessive microwave energy:

1. Read all instructions before using the appliance.
2. Read and follow the specific **PRECAUTIONS TO AVOID POSSIBLE EXPOSURE TO EXCESSIVE MICROWAVE ENERGY** found on pages iii & iv.
3. This appliance must be grounded. Connect only to properly grounded outlet. See **GROUNDING INSTRUCTIONS** found on page v.
4. Install or locate this appliance only in accordance with the provided installation instructions.
5. Some products such as whole eggs and sealed containers - for example, closed glass jars - may explode and **SHOULD NOT** be heated in this oven.
6. Use this appliance only for its intended use as described in the manual. **DO NOT** use corrosive chemicals or vapors in this appliance. This type of oven is specifically designed to heat, cook, or dry food. It is **NOT** designed for industrial or laboratory use.
7. Children **SHOULD NOT** use this appliance.
8. **DO NOT** operate this appliance if it has a damaged cord or plug, if it is not working properly, or if it has been damaged or dropped. See **POWER SUPPLY CORD REPLACEMENT** found on page v.
9. This appliance should be serviced only by qualified service personnel. Contact the nearest authorized service facility for examination, repair or adjustment.
10. **DO NOT** cover or block any openings on the appliance.
11. **DO NOT** store this appliance outdoors. **DO NOT** use this product near water - for example, near a kitchen sink, in a wet basement, or near a swimming pool.
12. **DO NOT** immerse cord or plug in water.
13. Keep cord away; from heated surfaces.
14. **DO NOT** let cord hang over edge of table or counter.
15. **DO NOT** use a water jet for cleaning.
16. See the Maintenance section of this manual.
17. To reduce the risk of fire in the oven cavity:
 - a) **DO NOT** overcook food. Carefully attend appliance if paper, plastic, or other combustible materials are placed inside the oven to facilitate cooking.
 - b) Remove wire twist-ties from paper or plastic bag in oven.
 - c) If materials inside the oven should ignite, keep oven door closed, turn oven off, and disconnect the power cord, or shut off power at the fuse or circuit breaker panel.
 - d) **DO NOT** use the cavity for storage purposes. **DO NOT** leave paper products, cooking utensils, or food in the cavity when not in use.

SAVE THESE INSTRUCTIONS

PRECAUTIONS TO AVOID POSSIBLE EXPOSURE TO EXCESSIVE MICROWAVE ENERGY

1. **DO NOT** attempt to operate this oven with the door open since open-door operation can result in harmful exposure to microwave energy. It is important not to defeat or tamper with the safety interlocks.
2. **DO NOT** place any object between the oven front face and the door or allow soil or cleaner residue to accumulate on the sealing surfaces.
3. **DO NOT** operate the oven if it is damaged. It is particularly important that the oven door close properly and that there is no damage to the:
 - a) Door (bent).
 - b) Hinges and latches (broken or loosened).
 - c) Door seals and sealing surfaces.
4. The oven **SHOULD NOT** be adjusted or repaired by anyone except properly qualified service personnel.

SAVE THESE INSTRUCTIONS

PRECAUTIONS TO BE OBSERVED BEFORE AND DURING SERVICING TO AVOID POSSIBLE EXPOSURE TO EXCESSIVE MICROWAVE ENERGY

1. DO NOT operate or allow the oven to be operated with the door open.
2. Make the following safety checks on all ovens to be serviced before activating the magnetron or other microwave source, and make repairs as necessary:
 - a) Interlock operation.
 - b) Proper door closing.
 - c) Seal and sealing surfaces (arcing, wear, and other damage).
 - d) Damage to or loosening of hinges and latches.
 - e) Evidence of dropping or abuse.
3. Before turning on microwave power for any service test or inspection within the microwave generating compartments, check the magnetron, wave guide, or transmission line, and cavity for proper alignment, integrity, and connection.
4. If the oven is operative prior to servicing, a microwave emission check should be performed prior to servicing the oven. Refer to page 6-2 of this manual for microwave leakage testing procedure.
5. Any defective or mis-aligned components in the interlock, monitor, door seal, and microwave generation and transmission systems shall be repaired, replaced, or adjusted by procedures described in this manual before the oven is released to the owner.
6. A microwave leakage check to verify compliance with the Federal Performance Standard **MUST BE** performed on each oven prior to release to the owner. Refer to page 6-2 of this manual for microwave leakage testing procedure.

SAVE THESE INSTRUCTIONS

GROUNDING INSTRUCTIONS

This appliance **MUST BE** grounded. In the event of an electrical short circuit, grounding reduces the risk of electric shock by providing an escape wire for the electric current. This appliance is equipped with a cord having a grounding wire with a grounding plug. The plug must be plugged into an outlet that is properly installed and grounded.



WARNING!!

Improper use of the grounding can result in a risk of electric shock.

Consult a qualified electrician or serviceman if the grounding instructions are not completely understood, or if doubt exists as to whether the appliance is properly grounded.

DO NOT use an extension cord. If the power supply cord is too short, have a qualified electrician or serviceman install an outlet near the appliance.

POWER SUPPLY CORD REPLACEMENT

If the power supply cord is damaged, it **MUST BE** replaced by the manufacturer or its service agent or a similarly qualified person in order to avoid a hazard.

General Note about Construction

Please be advised that the TurboChef C3 series ovens are manufactured in various locations, as such the C3/C and C3/Cmult are constructed using the Metric System. Therefore, it is very important to note the model number of the unit you are servicing to ensure you get the correct Metric component. Care has been given in this manual to list the different part numbers for the Metric and Imperial (C3/AB and C3Multi) ovens. In addition, please note that most hardware on the C3/C and C3/Cmulti oven is metric unless otherwise specified.

SAVE THESE INSTRUCTIONS

RF INTERFERENCE CONSIDERATIONS

This oven generates radio frequency signals. This device has been tested and determined to be in compliance with applicable part of FCC part 18 requirements and to the protection requirements of Council Directive 89/336/EEC on the approximation of the laws of the Member States relating to electromagnetic compatibility at the time of manufacture. However, some other equipment may exhibit sensitivity to signals below these limits resulting in interference with that equipment.

If your equipment experiences interference, the following steps should be considered:

1. Increase the physical separation between this oven and the sensitive equipment.
2. If the sensitive device can be grounded, do so following accepted grounding practices.
3. If battery powered microphones are being affected, insure that the batteries are fully charged.
4. Keep sensitive equipment on electrically separate circuits, if possible.
5. **DO NOT** route intercom wires, microphone wires, or speaker cables near oven.

SAVE THESE INSTRUCTIONS

CHAPTER 1

INSTALLATION SPECS

TurboChef Technologies, Inc. C series

OVEN DESCRIPTION

SPECIFICATIONS	C3/AB, C3MULTI, C3/C, AND C3/CMULTI
Dimensions (single unit)	29" W x 25.5" H x 29.5" D (73.66 cm x 64.77 cm x 74.93 cm)
Dimensions (double stacked units)	29" W x 43" H x 29.5" D (73.66 cm x 109.22 cm x 74.93 cm)
Maximum Input	7.2 kW
Power Supply	208 VAC, 60Hz, 1 ϕ , 35 amp, 3 wire including ground
US (1 ϕ) All Models	240 VAC, 60 Hz, 1 ϕ , 30 amp, 3 wire including ground
Europe(1 ϕ) All Models	230-240 VAC, 50 Hz, 1 ϕ , 30 amp, 3 wire including ground
US (3 ϕ) C3Multi and C3/Cmulti	208 VAC, 60Hz, 3 ϕ , Delta, 30 amp, 4 wire including ground 240 VAC, 60 Hz, 3 ϕ , Delta, 22 amp, 4 wire including ground
Europe (3 ϕ) C3Multi and C3/Cmulti	380-415 VAC, 50 HZ, 3 ϕ , WYE, 15 Amp, 5 wire including ground 230-240 VAC, 50 HZ, 3 ϕ , Delta, 22 Amp, 4 wire including ground
Microwave Frequency	2.45 GHz
Connections including ground	The unit is supplied with a 6' power cord that includes: US (1 ϕ) NEMA 6-50P Europe(1ϕ) 32A IEC 60309 plug US (3 ϕ) NEMA 15-50P Europe(3ϕ) 32A IEC 5 Pin plug The outlet box, receptacle, and wall plate are to be furnished by the installing contractor.
Maximum Power Usage	
Convection Oven	5.2 kW
Microwave Oven	2.0 kW

TABLE 1 - 1 Oven Specifications

INSTALLATION

The TurboChef Technologies, Inc. oven is manufactured to comply with applicable CE, ETL, FDA, and FCC requirements. In addition, the unit is ETL classified to NSF 4. Note: Some European models may or may not be certified under US FDA and/or ETL regulations. All equipment is designed and certified for safe operation when installed in accordance with local and/or national codes. Many local codes exist, and it is the responsibility of the owner and installer to comply with these codes. In addition, if the oven is not UL or ETL listed it MAY NOT BE USED or SOLD in the U.S.A or any of its territories.

In no event shall the manufacturer assume any liability for damages or injuries resulting from installations which are not in compliance with the instructions and codes listed above.



WARNING!!

DEATH, INJURY, AND EQUIPMENT DAMAGE could result from improper installation of this oven or installation of an oven which has been damaged during shipment or storage. Either of these conditions could void the equipment warranty.

DO NOT INSTALL an oven suspected of damage.

INSTALL this oven according to the policies and procedures outlined in this manual.

OVEN LOCATION

The well planned and proper placement of your oven will result in long term operator convenience and satisfactory performance.

Be sure to place the oven in an area which is accessible for proper operation and servicing.

The countertop or work surface must be able to support the weight of 250 pounds. The manufacturer shall not assume liability for damage or injury resulting from improper installation of equipment including temporary or unstable work stations or countertops.

There must be 2" (5.08 cm) between the top of the unit and any shelf or other surface.

The oven must be installed level front to back and side to side. The oven legs may be bolted to the counter top if desired.

Countertop surface must be at least 30 inches deep. Operator is responsible for proper placement on the countertop. TurboChef will not be responsible should an oven fall off a countertop due to improper placement or use by the customer. Oven placement shall be readily accessible by a service agent. Additional charges may be incurred by the customer should product placement mandate required service labor charges due to accessibility to the unit.

CHAPTER 2

CLEANING & OPERATING

BASIC CLEANING PROCEDURES

PROBLEMS ASSOCIATED WITH IMPROPER CLEANING

The oven may not be operating correctly because it is not being cleaned properly. If the door is leaking microwaves, erratic operation of the display and other electrical components can occur. Also food deposits left in the oven will turn into black carbon from the high heat. Carbon can cause arcing inside the cooking area and can reflect energy back to the magnetron.

If a customer tells you they are experiencing cooking performance problems, carefully inspect the cooking platter and waveguide cap for chips. If the platter or waveguide cap are chipped and soaked in water, they will absorb the water. The water will then be heated instead of the food product. The chipped part must be replaced.

DAILY CLEANING

1. Carefully remove the ceramic cooking platter and wave-guide cap. Spray both pieces **only with TurboCare® Oven Cleaner** and set aside to allow the cleaner to penetrate. **DO NOT soak the Ceramic Cook Platter or Waveguide Cap in water.**

2. Clean the ceramic cooking platter, and wave guide cap using brushes and scrub pads. Rinse to remove all cleaner and debris. Inspect for damage and replace as required.
3. **Reinstall the clean wave-guide cap into the oven.** This will protect the wave-guide seal while the cook chamber is cleaned.
4. To clean the interior of the oven, use a 3"x5" green scrub pad. Use **only TurboCare® Oven Cleaner** on tough spots. **DO NOT** wash out the interior cooking area. The waveguide quartz seal is not a water tight seal. Wipe out the oven with a damp rag. If the door area needs cleaning, be careful not to damage the small rubber gasket around the door shunt area.
5. Remove the lower access panel and grease collection pan. Empty, clean and reinstall the pan.
6. Verify the louvers on the front and side of the oven are clean of lint and unobstructed.

MONTHLY CLEANING

Remove and clean the exhaust cover from the back of the oven.

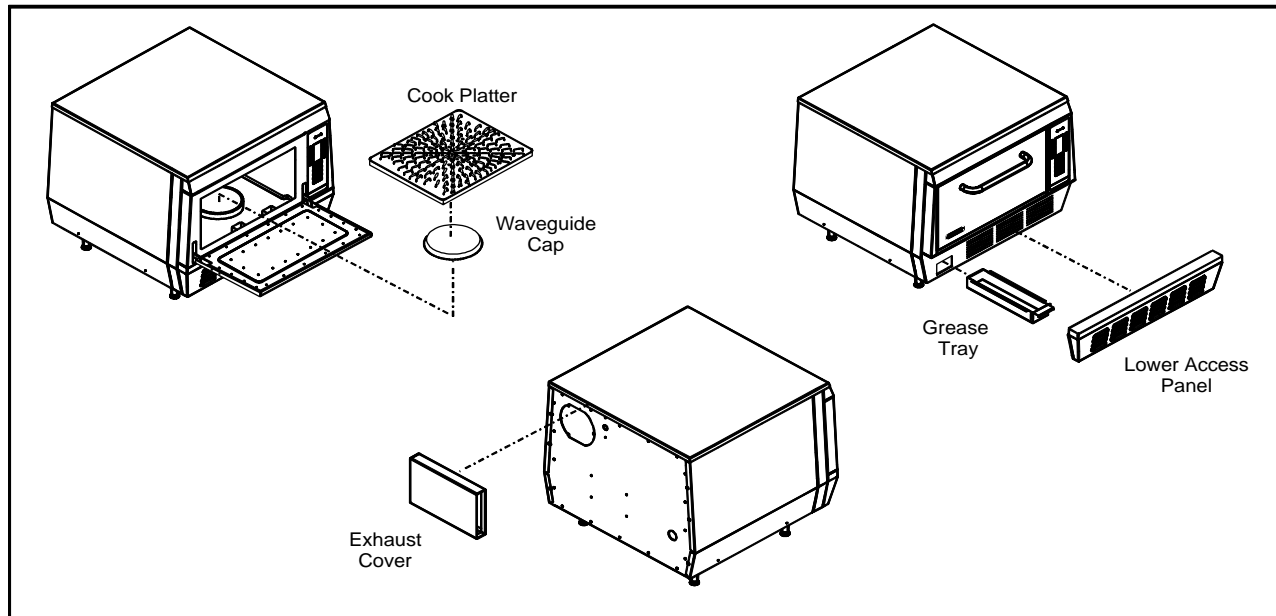

FIGURE 2 - 1 Cleaning

CHAPTER 3

THEORY OF OPERATION

INTRODUCTION

The TurboChef C3/C oven utilizes two independent heat transfer mechanisms in order to rapidly cook food. The systems are as follows: Convection and Microwave energy. By combining these mechanisms and with our ability to control each mechanism independently, we are able to reduce the cook time of most foods by 70%-90%.

For the purpose of this manual we will identify each independent heat transfer mechanism individually. For instance, if an oven is experiencing difficulties browning the food, you know to focus on the Convection Circuit not the Microwave System. If an oven is browning the food but not heating the food, you will know to focus on the Microwave System.

The following block diagram represents the oven's different systems and their critical components. If you are experiencing problems with any of the components listed below, please turn to the appropriate section.

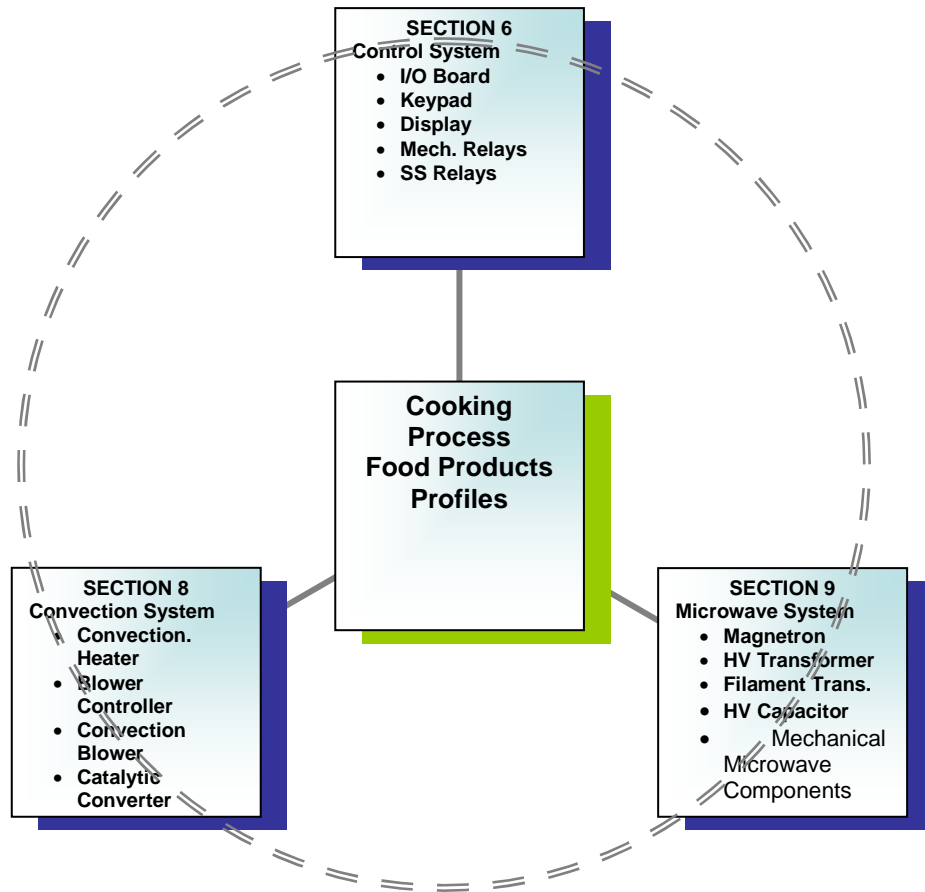

GLOSSARY OF COMMON OPERATING TERMS

Display - Primary interface to relay messages to the operator.

Keypad - Primary interface for the operator to control the oven.

Cook Chamber - Cavity in which the food products are cooked.

PRODUCT RECIPES

Recipe - The food product recipe programming consists of total time, percent of total time per event, percentage of hot air flow (AIR) required and microwave (MW) level required.

Cook Cycle - Total time of operation for a recipe.

Cook Event – Segment of a recipe, up to 6 events can be used for each recipe.

Duration - Time, in percent of total time of a single cook event.

Air - Percent of convection air flow during a cook event.

MW - Percent of microwave used during a cook event.

Cook Temperature Set Point - Temperature should be a constant parameter. The same cook temperature should be used by all cook recipes.

MODES

Mode – The software environment which allows certain operations to occur. There are several modes, STANDBY, COOK, WARM UP and COOL DOWN in which the oven can operate.

Standby Mode - The standby mode is similar to oven off. In standby there is no power to the oven. There is power to the control, however, the oven will not operate in standby mode.

Cook Mode - Mode used to perform the normal oven operations, such as, monitor the key pad for requests to cook or change mode, and maintain the oven at the cook temperature set point.

Warm-Up Mode - Mode to bring the oven up to the cook temperature set point.

Cool-Down Mode - Turns off all oven components except the cooling fan and circulation blower.

Programing

Edit Mode

Edit mode enables the operator to alter Recipes and the Cook Chamber Temperature (CC). To Access Edit Mode, press the “Up” and “Down” Arrows Keys on the keypad simultaneously. When prompted, enter the Access Code “9” and then press “Enter”.

Changing the Cook Chamber Temperature

The first screen in Edit Mode allows you to change the Cook Chamber Temperature (CC) by pressing the “Up” and “Down” Arrow Keys. The operator may adjust the temperature between 350°F and 525°F in 25°F increments. Once you have selected the desired temperature, press the “Enter” Key to set CC.

Altering a Recipe

The C3 oven control has 64 unique Recipes available for the operator. The Display will show 1 page of 8 Recipe Groups. Each Recipe Group contains 8 Subgroups or Recipes. See Figures 3-1 and 3-2.

To alter a Recipe, enter Edit Mode as described above. After you have entered the Access Code and set CC, the screen will display the 1st set of 8 Recipe Groups.

Now select the Recipe Group that contains the individual Recipe you wish to alter. Next, select which Recipe you wish to alter by pressing the Soft-Key corresponding to the Recipe Item. See Figure 3-2.

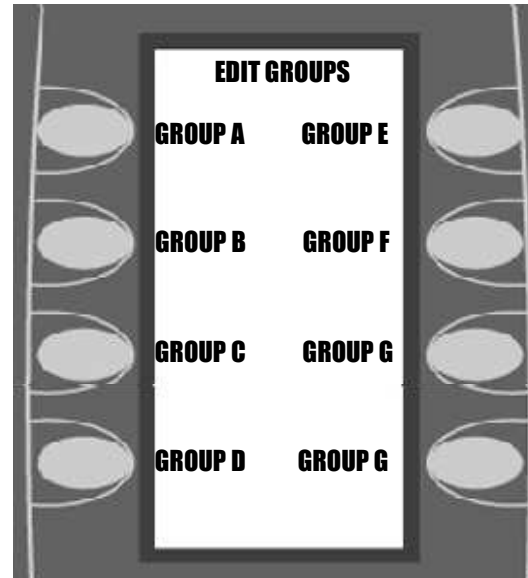

Figure 3-1: Edit Groups

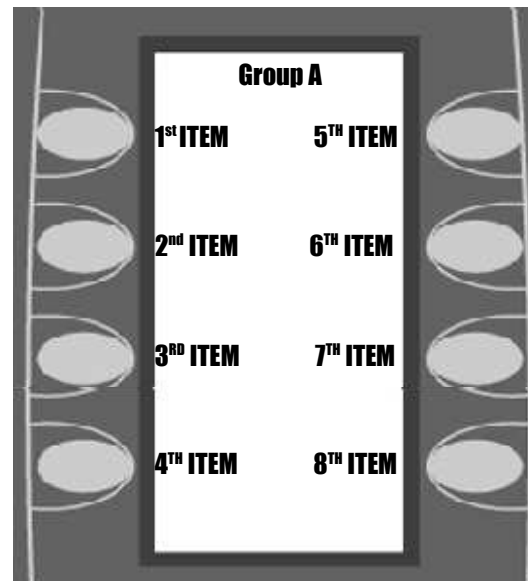

Figure 3-2: Edit Groups

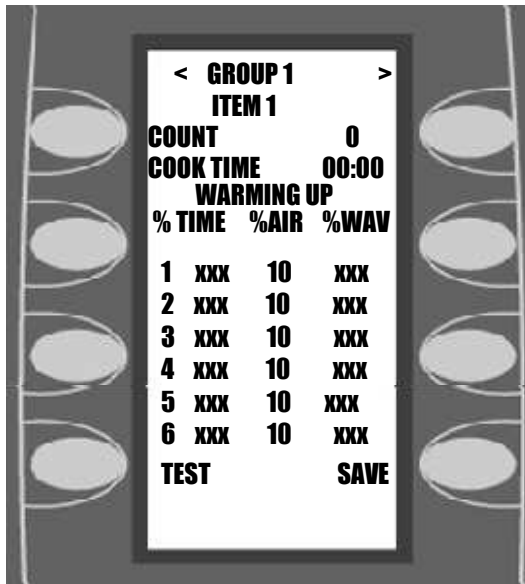

Figure 3-3: Edit Groups

Use the “Up” and “Down” keys to navigate through a Recipe and use the Keypad and the “Enter” key to alter any of the following parameters:

COOK TIME: Total duration of the Cook Cycle. Enter the desired time and press “Enter”. Valid times are between 1 second and 5 minutes.

Events 1...6: Use the keypad and “Enter” key to enter values for % Time, % Air and % MW.

The % Time for all Events must total to 100%. The operating system will not allow a combination of Events that do not total to 100% or exceed 100%.

The % Air parameter is valid between 10 and 100%. Note: If an Event is unused, the %Air parameter may be displayed as 0%. It is only a default.

The % MW parameter is valid between 0 and 100%.

Once the desired changes have been made, you may test the recipe by pressing the “Test” Soft-Key. This will execute the displayed recipe. Once you are satisfied with the Recipe, press “Save” to permanently store your changes. Press the “Back Arrow” 4 times to exit the Edit mode.

User Configurable Options:

The user may enable or disable the following options:

Edit Mode: For security purposes the Edit Mode can be disabled by pressing the “Back Arrow” and “Enter” keys simultaneously and entering the Access Pin: “T-I-D-E” & “Enter”. When prompted select either “9” to re-enable Edit Mode or any other key to disable Edit Mode.

Done State: The Done State (Figure 3-4) can be removed to eliminate the option to Save an altered Time or the option to Cook More.

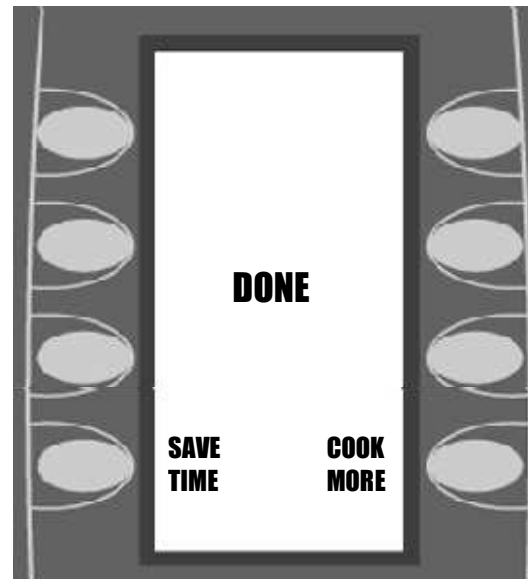

Figure 3-4: Done State

To disable the Done State, press the “Back Arrow” and “Enter” keys simultaneously and Enter the Access Pin “D-O-N-E” and Enter. When prompted, press “9” to re-enable or any other key to disable the Done State.

Time State: This state can be removed to prevent the User from adjusting the Total Cook Time prior to pressing the “Start” Soft Key to begin a Cook Cycle. See Figure 3-5.



Figure 3-5: Time State

To disable the Time State, press the "Back Arrow" and "Enter" keys simultaneously and

"Enter" the Access Pin "T-I-M-E" and "Enter". When prompted, press "9" to re-enable or any other key to disable the Time State.

Passwords

Edit Mode: "Back and "Enter" simultaneously. Enter Pin: "9" & "Enter".

Test Mode: "Back and "Enter" simultaneously. Enter Pin: "9-4-2-8" & "Enter".

Reset Control (Soft Restart): "Back and "Enter" simultaneously. Enter Pin: "9-4-7-1" & "Enter".

Erase: "Back and "Enter" simultaneously. Enter Pin: "3-7-2-7" & "Enter" When asked "Erase Menu" press "3".

Caution: The Erase command will PERMANENTLY DELETE all stored recipes and settings.

CHAPTER 4

FAULT CODES

Introduction

The C3C oven has the ability to continually monitor and log various fault conditions. Some fault conditions will terminate cook cycles, while others will not. Please refer to Table 4-1 for fault codes:

The Codes are listed in order of hierarchy. For example: If during cooking the oven experiences an F1 and F2 fault, the oven will only report a F1 fault since the software will halt all actions upon discovering the F1 fault.

In addition if a fault is detected the fault counter will increment. If the fault is cleared the fault counter will not de-increment.

View Fault Codes

To view the Fault Log, press the “4” and “6” keys simultaneously in the Off State. The oven will display all logged faults. See Figure 4-1.

Each Fault Register will log up 255 instances before rolling back to zero. The Cook Count will log up to 65,535 Cook Cycles. Note: In order for the Control to log a Cook Cycle, the oven must complete the 1st Event of any given recipe. If a Recipe only has 1 Event, the oven must complete the entire Cook Cycle in order to count the Cook Cycle.

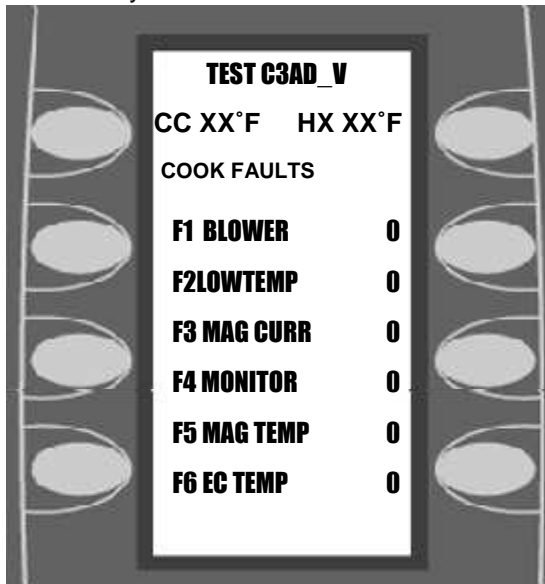

Figure 4-1: Fault

Fault Code Introduction:

Note: To reset Fault Counter, Press the “0” key.

LOW MAG CURR (HV BREAKDOWN) or F3 MAG CURR – the magnetron transformer is drawing less than 7 amps. The normal current draw is approximately 9 amps. The current draw is being monitored by the control board which has a current transformer mounted on it. See section 6

LOW COOK TEMP or F2 LOW TEMP– the temperature set for the C3 SERIES is not being maintained within 84°F (46°C) differential of the Cook Chamber Setpoint. It is referenced by the cook chamber type K thermocouple. Note: It may also be controlled by the heat exchanger thermocouple. See section 5

MAG OVER TMP or F5 MAG TEMP– the snap disk on the magnetron has overheated and has tripped. Reference Chpt. 9

BLOWER STATUS or F1 BLOWER – The control board is not receiving the proper output from the convection (blower) motor speed control. Reference Chpt. 8

ELEC OVR TMP (EC TMP HIGH) or F6 EC TEMP – The electronics compartment thermocouple connected to the control board has detected a temperature above 140°F (60°C). Reference Chpt. 6

OVEN DOOR OPEN – (during cook cycle) the cooking door has been opened during a cook cycle and has not been closed properly.

DOOR MONITOR or F4 MONITOR: -- The control board senses that the **Cook Door Monitor Switch** is out-of-sequence with the **Primary and/or Secondary Door Switches**. Reference Chpt. 7

HX RISE LOW - HX (Heater) Temperature has failed to rise 14°F (~8°C) F in 30 seconds. Reference Chpt. 8

NOTE: Some error codes may be different or no longer available or current. The following list details all error codes created since C3/AB, C3/C, C3CMulti and C3/AB-Multi no exceptions.

Fault Code Messages Matrix

Old Error Code	New Error Code	Warm-Up	While Cooking	Self-Test	Reference Chapter
BLOWER STATUS	F3 BLOWER	X	X	X	8
LOW COOK TMP	F2 LOW TEMP		X		8
LOW MAG CURR	F3 MAG CURR		X	X	9
DOOR MONITOR	F4 MONITOR		X		7
MAG OVER TMP	F5 MAG TEMP	X	X	X	9
ELEC OVR TMP	F6 EC TEMP	X	X	X	6
HX RISE LOW	Same	X		X	8
THERMO OPEN	Same	X	X	X	8
OVEN DOOR AJAR	Same	X	X	X	7
EC TEMP HIGH	F6 EC TEMP	X	X	X	6
CLOSE OVEN DOOR	same	X	X	X	7

TABLE 4-1

Notes:

1. All Fault Codes listed in **BOLD** will terminate a Cook Cycle upon discovery.
2. Any fault occurrence during Cook mode will be logged in the Fault Counter.
3. ELEC OVR TMP/EC TEMP HIGH/F6 fault code will not terminate a cook cycle, however it will alert the user of a possible air circulation problem (Page 6-10)

CHAPTER 5

TEST

Test Mode

TO ENTER TEST FUNCTION MODE

1. From the standby mode, press and hold both **BACK** and **ENTER** keys simultaneously.
2. The display reads:
ENTER ACCESS CODE
3. Use the NUMERIC keypad to enter the following access code:
9- 4- 2- 8 (Older Ovens 8- 3- 1- 7)
4. Press the ENTER key.

TEST FUNCTION OPTIONS

The test screen displays the CC (cook cavity) and HX (heat exchange) temperature at the top of the screen.

The control displays page one of the test function options. Press the DOWN ARROW key to display page two of the test functions options.

To access a test function, press the corresponding soft key repeatedly.

Blower Speed

The BLOWER key increments the blower speed in 10% steps. When the blower speed is 100%, the next press sets the speed to 0%.

Electronic Compartment Temperature

The °ELEC key displays the temperature inside the electronic enclosure.

Self Test Function

The STEST key initiates a self-test function to test all major components of the oven. Press the L4 key once to run the Self Test. Press the BACK key to return to the standby mode.

Heater Test

The HEATER key turns the heater on or off. If the heaters are on, pressing the key turns the heaters off. If the heaters are off and the maximum (HX) temperature (900°F) is not exceeded, pressing the HEATER key turns the heaters on. If the blower speed is 0, the blower speed is set to the Idle Airflow.

Magnetron

The MGTRON key is a press and hold key to test the magnetron. If the magnetron filaments are off when the MGTRON key is pressed, the message "MAG WARMING UP" is displayed. After a 3 second delay or if the filaments are already on, "MAG ON, RF xxx" is displayed. "xxx" is the

fluctuating microwave power measured in the wave-guide. Any time the MGTRON key is released, the magnetron turns off. The filament power (magnetron cooling fan and mode stirrer) remains on for three minutes.

NOTE: The RF power indication is optional on the C3/C SERIES model oven.

Diagnostic Display

The DIAG key turns on or off the diagnostic display feature. This feature adds temperature displays to the menu group screens.

While cooking, cook setting parameters are displayed when diagnostics are enabled.

With diagnostics enabled, status indicators are displayed on the lower left of the display. Each indicator is a letter, which is displayed in a positive sense when the status condition is on. The letter is reversed when the condition is off.

Status Indicators

There are eight status indicators:

- **P** - Cook door primary interlock switch
- **S** - Cook door secondary interlock switch
- **M** - Cook door monitor interlock switch
- **t** - Magnetron over temperature switch
- **h** - Heater turn on command
- **H** - Heater current detected
- **A** - Blower motor speed control "run" status
- **W** - Magnetron current detected

Example: When the status indicator is highlighted, for example **M**, the status is open or null. In this case, the Monitor switch is in the Open State.

Serial Number

NOTE: This should only be needed when installing a new control. The S/N is located on the back of the oven OR behind the bottom access panel.

The first press of the S/N key displays the oven's seven-digit serial number. Use the following procedure to enter the serial number.

1. Press the S/N key again to enter the edit mode.
2. Right and left arrow key appear on either side of the serial number. These arrows are used to navigate within the text. Use the top left SOFT KEY to move the cursor to the left.

3. Use the top right SOFT KEY to move the cursor to the right.
4. Use the NUMERIC KEYPAD to change the digits as follows:
 - A) Press the key once to enter the number.
 - B) Press the key twice to enter the first letter.
 - C) Press the key three times to enter the second letter.
 - D) Press the key four times to enter the third letter.
 - E) Press the key five times to enter the fourth letter; if applicable.
5. Press the ENTER KEY to store the new number.

Cook Cycle Count

The CCC key displays the cook cycle count. The count is incremented when the cook process completes at least the first event. The count includes test cooks selected while in the edit function. To reset the count, press the zero "0" key.

PIN Number

The PIN key is used to enter a new personal identification number (password) for accessing the edit function. When the button is pressed the display reads:

ENTER PIN _ _ _ _

Use the numeric keypad to enter the new PIN. Only numbers are applicable for the PIN.

Temperature Units

The F/C key alternately selects Fahrenheit or Celsius for temperature displays.

Cook Fault Counter

The FAULTS or FF key is used to read and reset the oven cook fault counters. Press the 0 key to reset the fault counter displayed. On ovens with FF repeat pressing the FF button to view all six fault counters. The faults include:

- BLOWER STATUS (blower motor speed controller)
- LOW COOK TMP (cooking temperature)
- LOW MAG CURR (microwave current)
- LOW MAG FLUC (rf power fluctuations)*
- MAG OVER TMP (magnetron over temperature switch)
- ELEC OVR TMP (electronics compartment over temperature detection)
- DOOR MONITOR: (cook door monitor switch out of sequence)*

* NOTE: The C3/C model and late model C3/AB oven will have the LOW MAG FLUC error message replaced by the DOOR MONITOR error message.

Idle Airflow

The first press of the IAF key displays the selected idle airflow. Subsequent presses of the IAF button increment the idle airflow in 10% steps from 20% to 50%. When the idle airflow is 50%, the next press sets the airflow to 20%. All ovens are factory set at 30%.

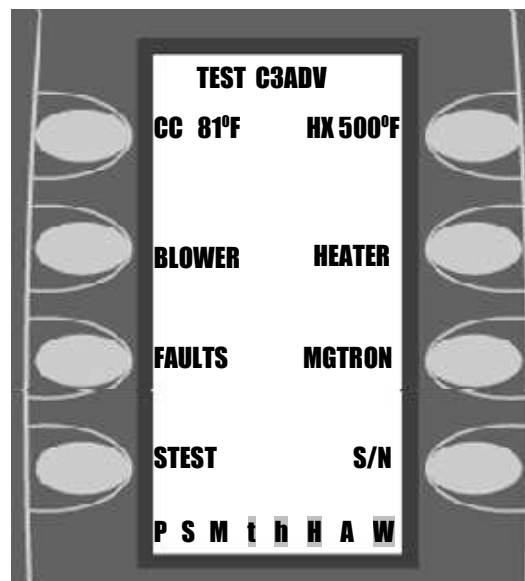

1st Screen: Test Mode

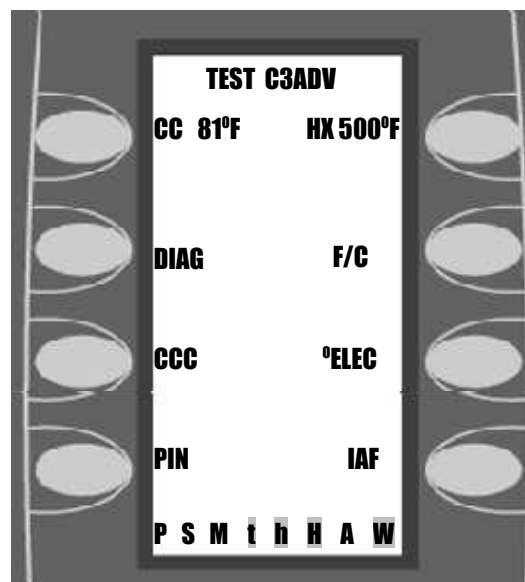

2nd Screen: Test Mode

PASSWORDS FOR OPERATING C3/C OVENS with C3AD Software Version

- ◆ To access **TEST/SERVICE** functions, press and hold BACK and ENTER keys. At the “Enter Pin _____” prompt, key in 9428 (Older ovens 8317) “WHAT” and press Enter. Reference Chapter 5
- ◆ To access recipe **EDIT**, press and hold Up and Down arrow keys. At the “Enter Pin _____” prompt, key in 9 (factory default, see Edit PIN below) and press Enter. Reference Chapter 3
- ◆ To select 208/240 VAC operation, press and hold BACK and ENTER keys. At the “Enter Pin _____” prompt, key in 8658 “VOLT” and press Enter. Follow screen instructions. When 208VAC is selected, the screen advances to 30/35 Amp selection. When 240VAC is selected, the screen advances to Heater Rating (208/240) selection. Follow screen instructions. Reference Chapter 8
- ◆ To change the PIN for recipe Edit (9 is factory default), press and hold BACK and ENTER keys. At the “Enter Pin _____” prompt, key in 3348 “EDIT” and press Enter. At the “Please Enter New PIN _____” prompt, key in from 1 to 4 digits and press Enter. Reference Chapter 3
- ◆ To enable or disable the “Please Place Food in Oven” screen, press and hold BACK and ENTER keys. At the “Enter Pin _____” prompt, key in 5623 “LOAD” and press Enter. At the “Load Screen” prompt, press 9 “Y” to enable the “load” screen, any other key turns off the “load” screen.
- ◆ To enable or disable the “Enter Cook Time” screen, press and hold BACK and ENTER keys. At the “Enter Pin _____” prompt, key in 8463 “TIME” and press Enter. At the “Time Screen” prompt, press 9 “Y” to enable the “time” screen, any other key turns off the “time” screen.
- ◆ To enable or disable the “Done, Save Time, Cook More” screen, press and hold BACK

and ENTER keys. At the “Enter Pin _____” prompt, key in 3663 “DONE” and press Enter. At the “Done Screen” prompt, press 9 “Y” to enable the “done” screen, any other key turns off the “done” screen.

Note: If you fail to timely enter the requested keys, the function “times out” and returns to the Oven Off screen without making any change.

CHAPTER 6

**ELECTRICAL & CONTROLS
SYSTEM**

Electrical Component Locations:

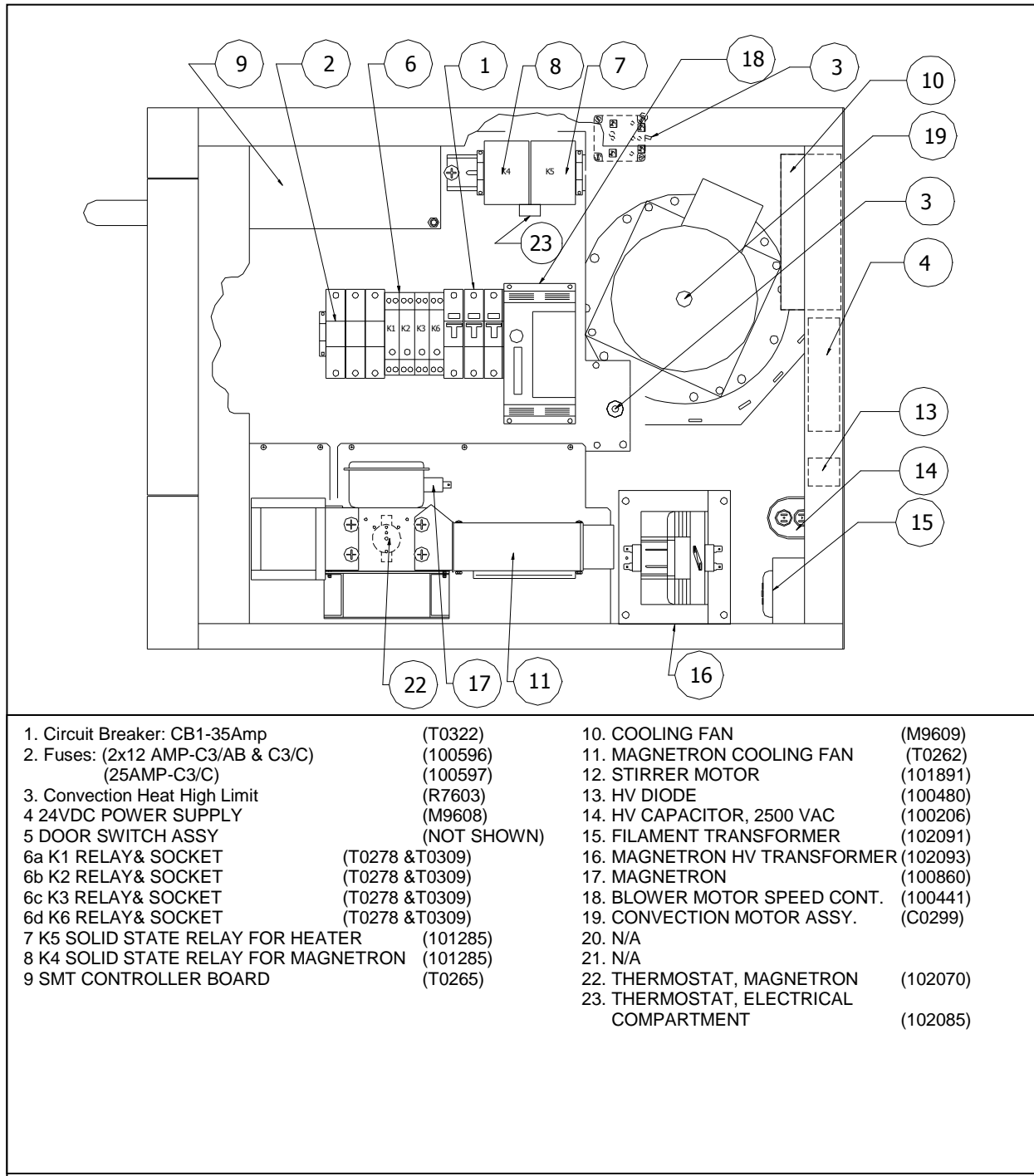
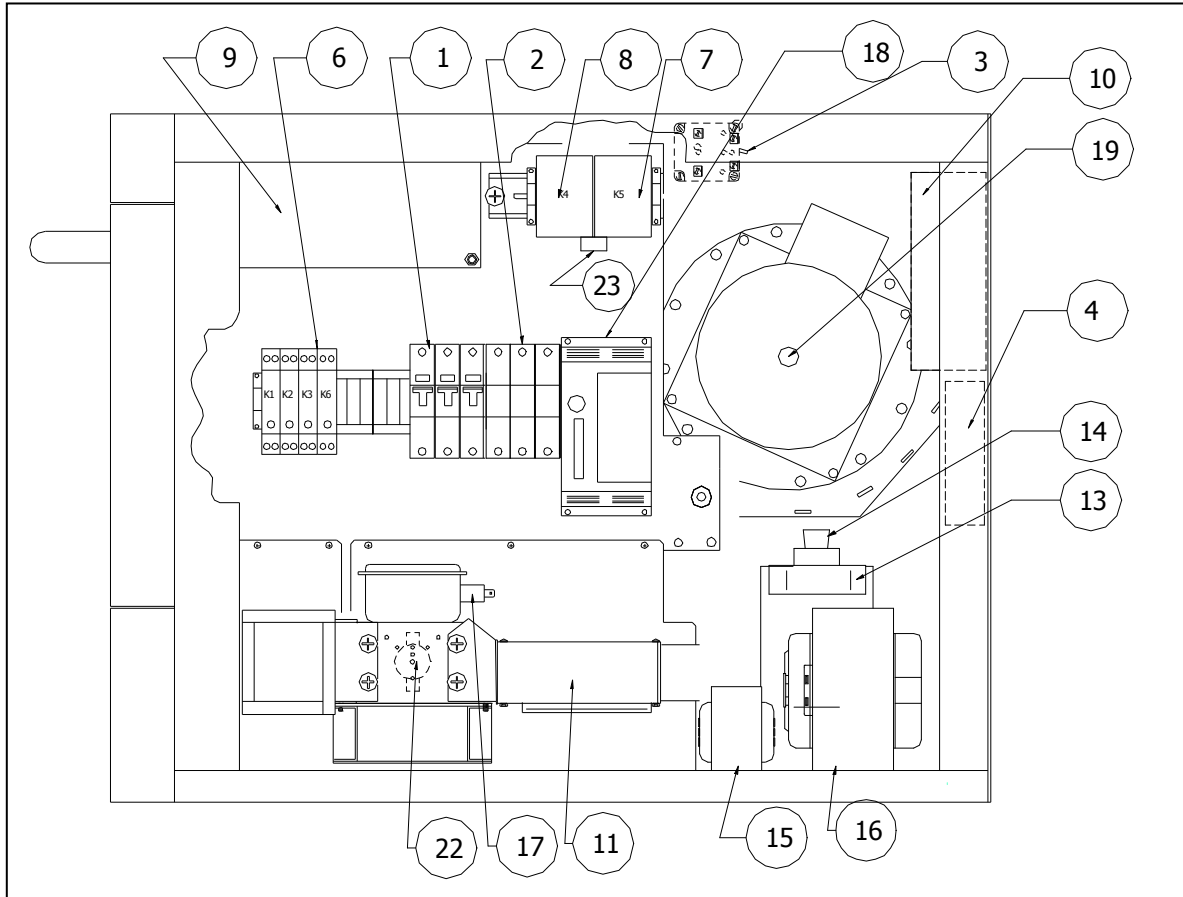

FIGURE 6-1a Electrical Component Locations C3/AB Only

Electrical Component Locations:



1. Circuit Breaker: CB1-35Amp with trip coil	(T0322)	10. COOLING FAN	(100519)
2. Fuses: (2x12 AMP-C3/AB & C3/C)	(100596)	11. MAGNETRON COOLING FAN	(T0262)
	(100597)	12. STIRRER MOTOR	(101891)
3. Convection Heat High Limit	(R7603)	13. HV DIODE	(100480)
4 24VDC POWER SUPPLY	(M9608)	14. HV CAPACITOR, 2500 VAC	(100206)
5	(NOT SHOWN)	15. FILAMENT TRANSFORMER	(102091)
6a K1 RELAY& SOCKET	(T0278 &T0309)	16. MAGNETRON HV TRANSFORMER	(102093)
6b K2 RELAY& SOCKET	(T0278 &T0309)	17. MAGNETRON	(100860)
6c K3 RELAY& SOCKET	(T0278 &T0309)	18. BLOWER MOTOR SPEED CONT.	(100441)
6d K6 RELAY& SOCKET	(T0278 &T0309)	19. CONVECTION MOTOR ASSY.	(T0299)
7 K5 SOLID STATE RELAY FOR HEATER	(101285)	20. N/A	
8 K4 SOLID STATE RELAY FOR MAGNETRON	(101285)	21. N/A	
9 SMT CONTROLLER BOARD	(T0265)	22. THERMOSTAT, MAGNETRON	(102070)
		23. THERMOSTAT, ELECTRICAL COMPARTMENT	(102085)

Part Number 100441-Reliance Blower Motor Speed Controller will be replaced by 100444-Delta Controller & FSB10034.doc
EMI FILTER (T0286) NOT SHOWN

FIGURE 6-1b Electrical Component Locations C3/C Only

ELECTRICAL COMPONENT LOCATIONS: “C3/MULTI” OVENS ONLY

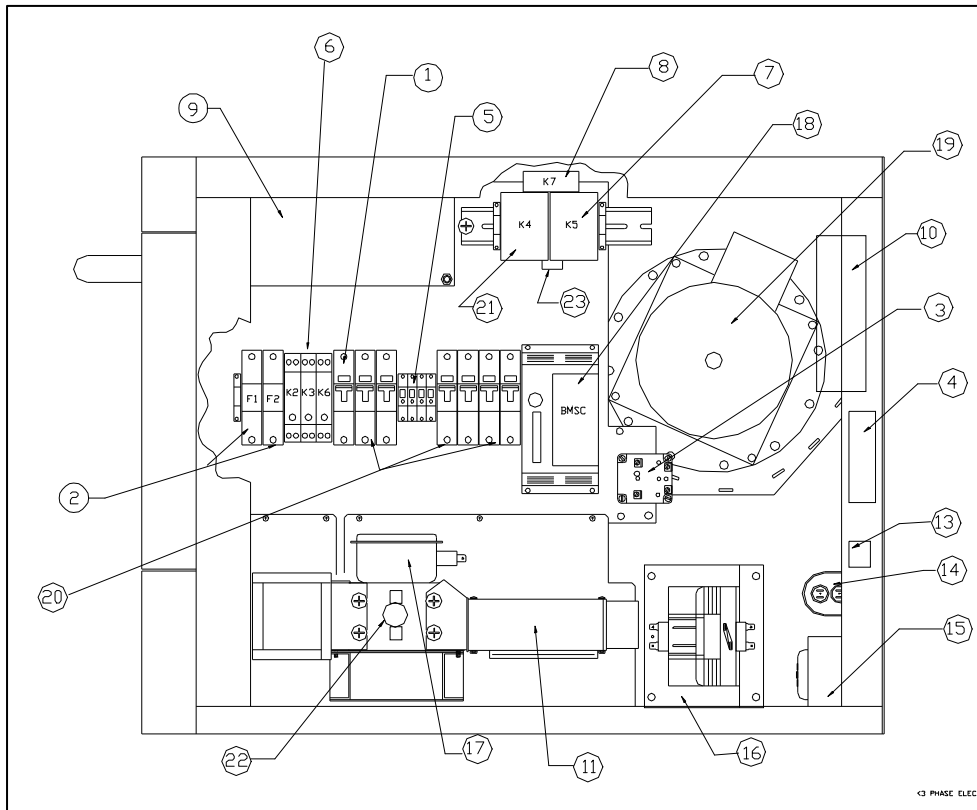

- | | |
|--|---|
| 1. Circuit Breaker: CB1-15A & CB2-15A&CB3-15A (103170) | 10. COOLING FAN (M9609) |
| 2. 12 A-FUSE ATM-12 (100596) | 11. MAGNETRON COOLING FAN (T0262) |
| 3. CONVECTION HEAT HIGH LIMIT (R7603) | 12. STIRRER MOTOR (101891) |
| 4. 24VDC POWER SUPPLY (M9608) | 13. HV DIODE (100480) |
| 5. DISTRIBUTION BLOCK (N/A) | 14. HV CAPACITOR, 2500 VAC (100206) |
| 6a. K2 RELAY & SOCKET (T0278 & T0309) | 15. FILAMENT TRANSFORMER (102091) |
| 6b. K3 RELAY & SOCKET (T0278 & T0309) | 16. MAGNETRON HV TRANSFORMER (102093) |
| 6c. K6 RELAY & SOCKET (T0278 & T0309) | 17. MAGNETRON (100860) |
| 7. K5 SOLID STATE RELAY FOR HEATER (101285) | 18. BLOWER MOTOR SPEED CONT. (100441) |
| 8. K4 SOLID STATE RELAY FOR MAGNETRON (101285) | 19. CONVECTION MOTOR ASSY. (C0299) |
| 9. SMT CONTROLLER BOARD (T0265) | 20. TRIP COIL BREAKER (103171) |
| | 21. K7 SOLID STATE RELAY HEATER (101285) |
| | 22. THERMOSTAT, MAGNETRON (102070) |
| | 23. THERMOSTAT, ELECTRICAL COMPARTMENT (102085) |

Notes:

Part Number 100441-Reliance Blower Motor Speed Controller will be replaced by 100444-Delta Controller & FSB10034.doc
EMI FILTER (100542) NOT SHOWN

FIGURE 6-1C Electrical Component Locations C3Multi Only

ELECTRICAL COMPONENT LOCATIONS: "C3/C MULTI" OVENS ONLY

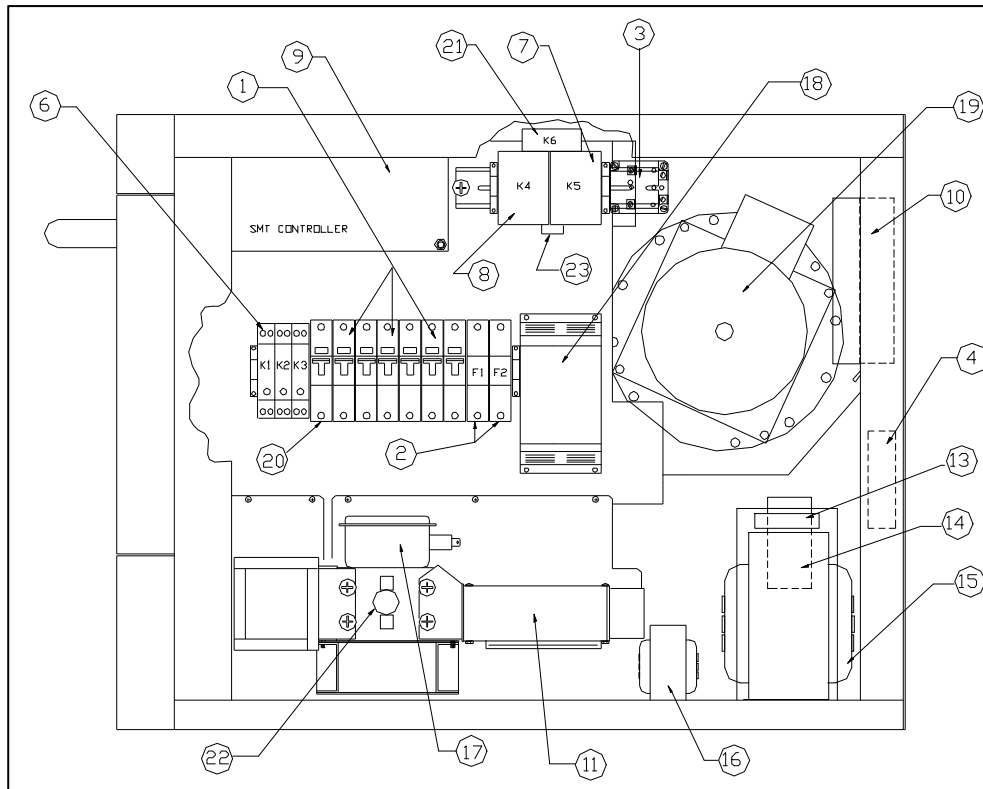

- | | | |
|--|---|--|
| 1. Circuit Breaker: CB1-15A & CB2-15A&CB3-15A (103170) | 10. COOLING FAN (100519) | |
| 2. 12 A-FUSE ATM-12 (100596) | 11. MAGNETRON COOLING FAN (T0262) | |
| 3. CONVECTION HIGH LIMIT (R7603) | 12. STIRRER MOTOR (101891) | |
| 4. 24VDC POWER SUPPLY (M9608) | 13. HV DIODE (100480) | |
| 5. DISTRIBUTION BLOCK (N/A) | 14. HV CAPACITOR, 2500 VAC (100206) | |
| 6a. K1 RELAY& SOCKET (T0278 &T0309) | 15. FILAMENT TRANSFORMER (102091) | |
| 6b. K2 RELAY& SOCKET (T0278 &T0309) | 16. MAGNETRON HV TRANSFORMER (102093) | |
| 6c. K3 RELAY& SOCKET (T0278 &T0309) | 17. MAGNETRON (100860) | |
| 7. K5 SOLID STATE RELAY FOR HEATER (101285) | *18. BLOWER MOTOR SPEED CONT. (100441) | |
| 8. K4 SOLID STATE RELAY FOR MAGNETRON (101285) | 19. CONVECTION MOTOR ASSY. (C0299) | |
| 9. SMT CONTROLLER BOARD (T0265) | 20. TRIP COIL BREAKER (103171) | |
| | 21. K6 SOLID STATE RELAY HEATER (101285) | |
| | 22. THERMOSTAT, MAGNETRON (102070) | |
| | 23. THERMOSTAT, ELECTRICAL COMPARTMENT (102085) | |

Notes:

Part Number 100441-Reliance Blower Motor Speed Controller will be replaced by 100444-Delta Controller & FSB10034.doc
EMI FILTER (100542) NOT SHOWN

FIGURE 6-1C Electrical Component Locations C3/CMulti Only

TurboChef Technologies, Inc. C Series

ELECTRICAL COMPONENTS PARTS LIST SUMMARY

Item #	Part Number	Description	Used on Model(s)
1	T0322	Circuit Breaker CB1-35A w/Trip Coil	C3/AB & C3/C
2	100596	12 Amp Aux Fuse	All
2b	100597	25 Amp Heater Fuse	C3/C
2c	100591	Fuse Holders	All
3	R7603	Convection High Limit	C3/AB & C3/C
3	102016	Convection High Limit	C3Multi & C3/CMulti
4	M9608	24 VDC Power Supply	All
6	T0278 & T0309	Relay (24 VDC Coil/240 VAC Output) & Socket	All
7	101285	Solid State Relay for Heater	All
8	101285	Solid State Relay for Magnetron	All
9	T0265	SMT Controller	All
10	M9609	Electrical Compartment Cooling Fan	C3/AB & C3Multi
10	100519	EBM Electrical Compartment Cooling Fan	C3/C & C3/CMulti
11	T0262	Magnetron Cooling Fan	All
12	101891	Stirrer Motor	All
13	100480	HV Diode	All
14	100206	HV, Capacitor, 2500 V	All
15	102091	Filament Transformer	All
16	102093	Magnetron Transformer T1	All
17	100860	Magnetron	All
18	100441	Blower Motor Speed Controller	All

ELECTRICAL COMPONENTS PARTS LIST (CON'T): All C Series Ovens-

Electrical Compartment and Controls

(See Figures 4-1a/b)

Item #	Part Number	Description	Used on Model(s)
19	C0299	Convection Motor Assy	All
20	103170	Circuit Breakers CB2 & CB3 15 Amp	C3Multi & C3/CMulti
21	101285	K7 Solid State Relay	C3Multi & C3/CMulti
22	102070	Thermostat, Magnetron (212F)	All
23	102085	Thermostat, EC Box	All
NS	100542	EMI Filters (not shown)	C3Multi & C3/CMulti
NS	T0286	EMI Filter	C3/AB & C3/C

CONTROL PANEL COMPONENT DETAIL

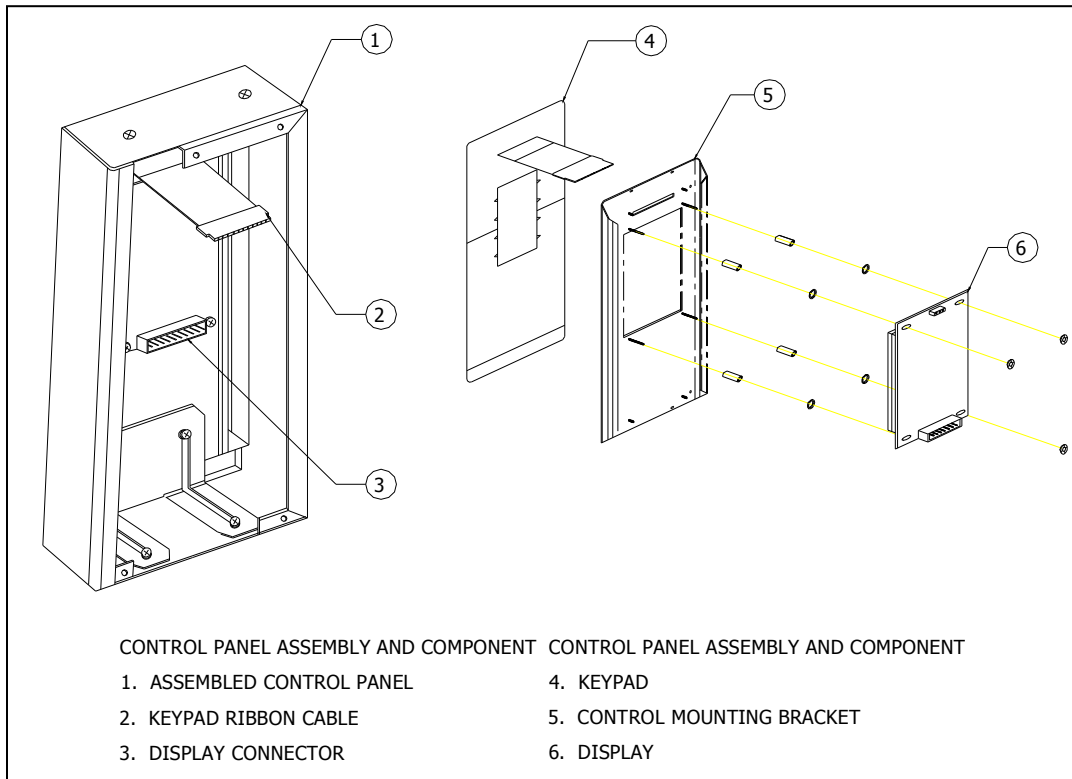

CONTROL PANEL PARTS LIST (see above)

ITEM	Part Number	Description	Used on Model(s)
1	T0239	CONTROL PANEL (SHEET METAL)	C3/AB & C3/MULTI
2	C0239	CONTROL PANEL (SHEET METAL)	C3/C & C3/CMULTI
3	NA	VFD DISPLAY CONNECTOR	All
4	T0264	KEYPAD	All
5	T0374	CONTROL MOUNTING PLATE	C3/AB & C3MULTI
5	C0374	CONTROL MOUNTING PLATE	C3/C & C3/CMULTI
6	T0238	VFD DISPLAY	All

CONTROL SYSTEM TROUBLESHOOTING

Issue:	Resolutions:
1: No Display (Blank)	<ol style="list-style-type: none"> 1. Verify power 208 VAC or 240 VAC is going to oven. If not correct voltage supply. 2. Does the control beep when any Key on the keypad is pressed? <ol style="list-style-type: none"> a. If no, check power going to the 24VDC power supply. Supply must have 208 or 240 VAC across L and N terminals. <ol style="list-style-type: none"> i. No Voltage: Change F1 and F2 Fuses. ii. Voltage OK: verify output of Power Supply is 24 VDC. <ol style="list-style-type: none"> 1. No Output: Disconnect Rear Cooling Fan from Power Supply and unplug unit from wall receptacle. Then reconnect oven <ol style="list-style-type: none"> a. If oven screen comes up then re-connect rear cooling fan back into circuit and short cooling fan thermostat. If unit display shuts down then replace Rear Cooling Fan. b. If oven screen comes up even with the rear cooling fan and thermostat shorted across, then place oven in TEST mode by pressing the BACK + ENTER simultaneously and keying 9-4-2-8 then Press the MGTRON key one time and if the display shuts down check for Loose Wire Connection or Magnetron Cooling Fan (shorted). 2. Output is 24VDC. Verify I/O Board has 24 VDC by checking the voltage on the D6 diode (striped end) to Chassis. Reference Chapter 10 for details <ol style="list-style-type: none"> a. No voltage: Check wires from Power Supply to I/O Board. b. Voltage is 24VDC, but 5VDC is not present on the I/O Boards J3 connector: Change I/O Board. Reference Chapter 10 for details. b. If Yes: Check all Connections between I/O board and Display. Correct any loose connections. If all connections OK and 5 VDC is present on J3 connector, but still no Display: Change Display.
2. No Keypad Input	<ol style="list-style-type: none"> 1. Check Keypad Ribbon Cable going to I/O Board. <ol style="list-style-type: none"> a. Cable and Connection Bad: Replace Keypad. b. Cable and Connection OK: Replace Keypad.
3. a. ELEC OVR TMP; "or" b. EC TEMP HIGH; "or" c. F6 EC TEMP	<ol style="list-style-type: none"> 1. Check operation of rear cooling fan. Reference Schematic in Chapter 10. 2. Check cooling air paths are not clogged or obstructed with grease residue. (front panel, rear fan grill, left and right side covers) 3. Verify there are no high heat or grease producing piece of equipment, such as a range top, open grill, fryer adjacent to the oven right side.

Defective Current Transformer on Computer Board

SMT Board (T0265) Background:

During the operation of the microwave system, the control board monitors current in the microwave circuit by means of a current transformer mounted on the controller board. The current transformer must see at least 6 amps in order for the microwave to energize. If it fails to register 6 amps, the I/O board may be defective and the oven will prematurely turn OFF the magnetron and display a "LOW MAG CURR/F3 MAG CURR" message.

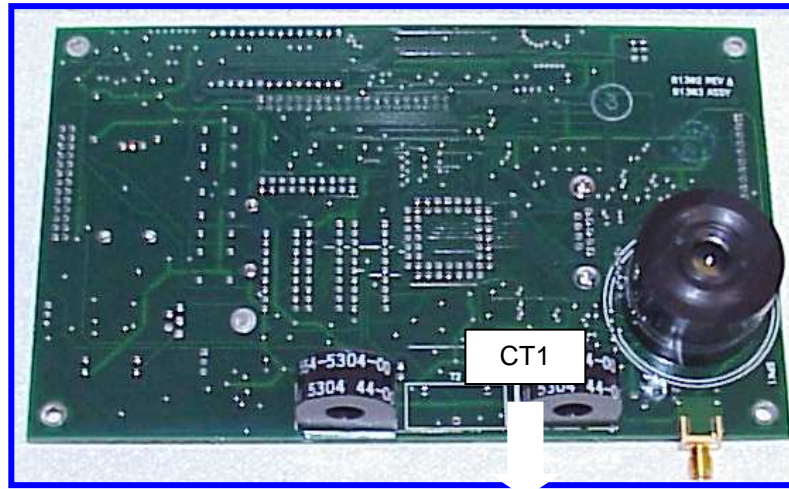

Figure 6-2: SMT Board (T0265)

Checking the controller current transformer

Step 1: Place oven in TEST mode. Press BACK key until the oven screen displays " OVEN OFF" then Press and hold the BACK and ENTER keys simultaneously and then key in PIN # 9-4-2-8 (access code) then ENTER. This will allow you to enter into the test mode to manually energize the magnetron.

Step 2: Place a load inside the oven (about 275ml of water or an approximate amount inside a coffee cup).

Step 3: Clamp an ammeter on K4-1 wire (same wire going thru CT1 on controller board), and energize the magnetron by pressing and holding the MGTRON key for about 10 seconds. If your meter measures current (approximately 9 Amps+/- 2) and the W indicator at the bottom of the screen does not un-highlight while energizing the magnetron, replace the computer board. If the measured current is between 6 and 7 Amps then double loop the wire thru CT1 twice, then perform a self test. If the self test fails then replace board.

CHAPTER 7

COOK DOOR ASSEMBLY

DOOR SWITCHES AND CIRCUIT BREAKER DOOR SWITCHES

The C series ovens have 3 door switches as mandated by law. The C3/AB and C3Multi have one door switch located on the left hand side (CDS) and is called the secondary switch. The other two switches are located on the right hand side (CDP & CDM). One is called the primary switch (CDP) and the other is called the monitor switch (CDM). The C3/C and C3/CMulti switch orientation is reversed, i.e., the monitor (CDM) and the primary switch (CDP) are located on the left side of the oven. The secondary (CDS) is located on the right side of the oven.

The monitor switch must close before the primary and secondary switches close (as the door is closed) or the circuit breaker will trip. If the primary or secondary switch is defective and not closing the screen will display a door open error message. To determine what sequence the doors are closing in, you will need to access the Test mode and activate the Test mode. By doing so, you will activate the status indicators at the lower left bottom of the display. Slowly close the door once you have activated the Test mode and observe the status indicators. As you close the door the **M** indicator must change from a highlighted state followed by the **S** indicator and final the **P** indicator. As you open the door, the sequence must reverse, i.e., **P**, **S** and then **M**. If this sequence is not correct, YOU MUST READJUST THE SWITCHES. See section 7-6.

"WHY DOES THE CIRCUIT BREAKER TRIPPED IF THE SWITCHES ARE MISALIGNED?"

"In addition to the High Voltage circuit, it is imperative to understand how the monitor circuit operates. The Monitor Circuit is a failsafe circuit that is designed to protect the operator if both the Primary and Secondary Interlock Switches fail to operate normally.

The Monitor Circuit consists of the Primary Interlock Switch, Secondary Interlock Switch, Monitor Safety Switch, Monitor Relay and Trip Coil. When the Cook Door closes during normal operation, the Monitor and Secondary/ Primary Switches close in this order. When all switches are closed, the microwave system is allowed to operate. If during normal operation, either Interlock Switch opens, such as when the Cook Door opens, the Control system will turn OFF the Microwaves; however, if the Monitor Switch opens before both the Primary and Secondary Interlock switches, i.e., abnormal operation, the Monitor switch will de-energize the Monitor Relay. When this occurs, a dead short is placed across L1 and L2. The short then trips the coil on the circuit breaker, which permanently interrupts power to the Microwave system, thus terminating a cook cycle if the oven was cooking and preventing the heaters from energizing. This then requires a service call from a qualified technician to assure that the monitor circuit is properly repaired to prevent excessive microwave radiation.

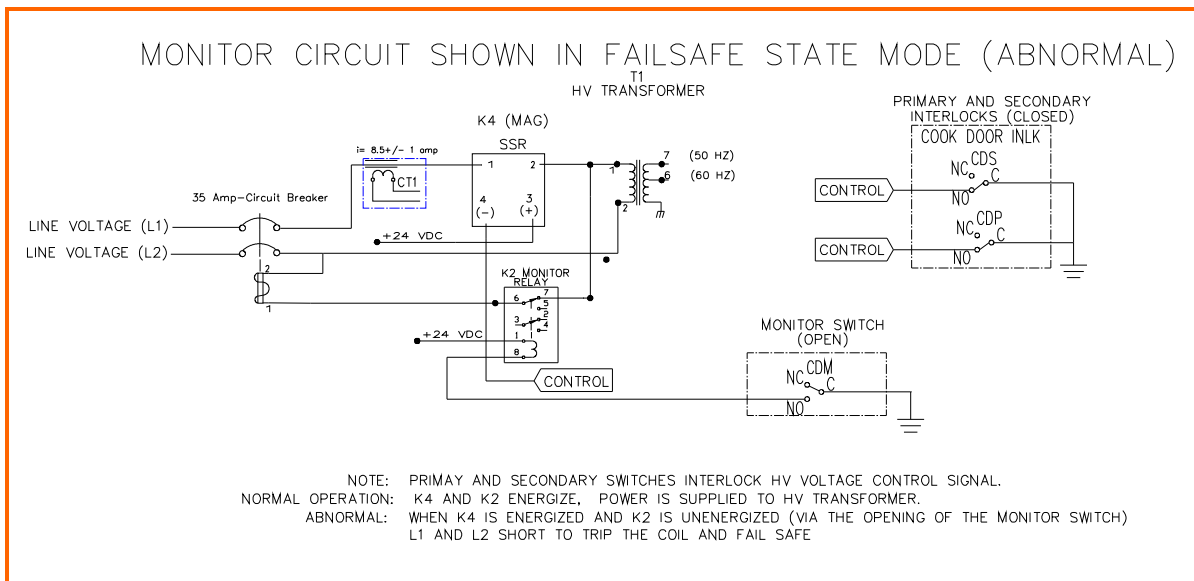

Figure 7-1

CIRCUIT BREAKER TRIP CHART	
Component	Possible Cause/Circuit Information
Magnetron transformer	The magnetron transformer will draw approximately 9 amps when functioning properly. Check winding resistances (See Page 9-8). A 3 Amp draw indicates the diode is defective.
Solid state contactor for Magnetron (K4)	The coil operates on 24v dc. Solid state relays tend to fail closed. Check with VOM meter. Reference Chapter 9 for troubleshooting.
Hot air heater element	Use VOM meter. 240V element is 12 ohms / current is 20amps. 208V element is 9 ohms / current is 23 amps. C3/C oven only: Check the 25 Amp fuse inline with the CB1 and the heater. Reference Chapter 8
Solid state contactor (K5) (K7) for hot air element	(See above for correct current draw.) The coil operates on 24v dc. Solid state relays tend to Fail closed. Check with VOM meter.
High limit & K1 relay (C3/AB and C3/C only)	High limit tripped (670°F/350°C). Reset high limit switch with screwdriver. Reference Page 8-4 for details
Door switch closure	Check Switches with VOM meter. Reference Page 7-2 & Figure 7-1 above.
Diode	The magnetron transformer will draw excessive current (greater than 15 amps), meaning the diode is shorted to ground. Reference Chpt.9

Table 7-1

DOOR SWITCH ADJUSTMENT

Tools Required:

- # 1 Phillips head screw driver
- # 2 Phillips head screw driver
- 3/8" socket wrench (1/4" drive)
- Needle nose pliers
- Large flat blade screw driver

GOAL

The goal of this adjustment procedure is to have the Monitor, Secondary and Primary switches close in that order as the oven door is closed. The switches must open in the reverse order as the door is opened, that is, the Primary, Secondary and then the Monitor open as the door opens. This procedure is written to insure proper oven operation and compliance with Federal regulations.

ADJUSTMENT

- 1) Remove the left and right side access covers (body sides).
- 2) Remove the lower louvered front access panel.
- 3) Remove oven top. It is secured in place with four 3/8" Nylock nuts to the upper frame sides.
- 4) Remove screw located on bottom of left side corner trim (front of oven) and carefully bend the trim out of the way to allow access to left side switch assembly and associated hardware. (See Fig. 7-6 a & 7-6b).

RIGHT SIDE OF OVEN:

NOTE: The C3/C and C3/Cmulti oven switch arrangement is different from the C3/AB and the C3Multi. The C3/AB and C3/Multi monitor and primary switches are on the right-hand side of the oven and the secondary switch is on the left-hand side of the oven. Regardless of their position on the oven, the procedure for adjusting the switches is the same for both types of ovens. See Figure 7-3.

5. Remove magnetron plenum assembly (secured by one PPH screw at rear of oven). The plenum assembly is located on the bottom right side of the oven.
6. On models C3/AB and C3Multi it may be necessary to remove the 35 AMP circuit breaker in order to gain access to the limit switches. If this is necessary, label each wire prior to removing it from the Circuit Breaker in the following step.
7. Carefully pull down two tabs on the bottom of the circuit breaker and pull the breaker up and out to remove it from the din rail

allowing access to the switch brackets on the right side of the oven

Note: Refer to page 7-11, DOOR ADJUSTMENT, along with this section if the cam follower bracket assembly has to be adjusted and tightened. **This is very important to prevent any potential damage to the door hardware from interference and to assure proper door closing tension.**

8. Check that the trailing arm is properly engaged in cam follower bracket assembly and trailing arm guide blocks. When the door is closed the trailing arms should sit as shown. See Figure 7-6a,b.
9. If the trailing arm is not properly engaged in cam follower bracket assembly or if it is hitting the assembly loosen the two 3/8" nuts securing the cam follower assembly.
10. Cam follower bracket assembly has clearance at the bottom to move. Pick up on trailing arm to engage it in trailing arm guide blocks and move cam follower bracket assembly up into notch on trailing arm. See Figure 7-4. Tighten the two 3/8" nuts when adjustment is correct.
11. When properly aligned, the door should have no play when pushed in the closed position and when opened the first movement of the trailing arm should be up and over the cam follower bracket assembly (both sides of the oven) – See Fig.7-4. Additionally, when the door is closed, the trailing arms should “snap” down into position. To test this, gentle pick up one of the trailing arms approximately 3/4 inch and release it. The trailing arm should “snap” back down in to the same position each time. If it hangs or does not return to the exact position each time readjust the cam roller assembly.
12. If it is determine that a proper adjustment can not be made, it may be necessary to reposition the bottom hinge on the door. To do this, loosen item 11 (see Figure 7-6) on both sides of the oven. With all screws loose, close the door and push in and down on the door. While doing so, tighten all screws on the hinge. Now repeat steps 7-10.

LIMIT SWITCH ADJUSTMENT: PRIMARY AND MONITOR

13. Actuator tab should be positioned as shown in Figure 7-5. It should be parallel to the primary switch lever. Adjust and bend (needle nose pliers) actuator tab as necessary.
14. When the door is closed and the actuator tab is in contact with the primary and monitor switches the switches should both be closed. The actuator tab should be in contact with the switch paddles such that when the switches are closed there is about 0.020" of clearance between the switch paddles and the switch bodies. Also, the actuator tab should be at or close to horizontal and be positioned approximately 1/4" from the end of the monitor switch actuator tab. Adjust the interlock switch brackets by loosening the screws as necessary. See Figure 7-5.
15. Once the switches and actuator are properly adjusted, as the door is opened the primary switch should disengage before the monitor switch.
20. As the door is opened slowly confirm that all three switches operate in the correct sequence, i.e. as the door is opened the switches open in the order of primary, secondary, and then monitor .
21. As the door is slowly closed confirm the switches close in the opposite order from above.
22. If the sequencing is not correct, readjust switch brackets and or associated hardware until all criteria are met.

SWITCH TEST AT TEMPERATURE:

LIMIT SWITCH ADJUSTMENT: SECONDARY

16. Refer to steps 8, 9, 10, and 11 this page. The trailing arm must be properly engaged in the cam follower bracket assembly and the trailing arm guide blocks.
17. Again, the actuator tab should be positioned as shown in detail of Figure 7-5. Adjust and bend (needle nose pliers) actuator tab as necessary.
18. When the door is closed, the actuator tab is in contact with the secondary switch paddle and the switch should be closed. There should be approximately 0.020" of clearance between the switch paddle and the switch body. Adjust the limit switch bracket by loosening the screws as necessary.
23. Reinstall main circuit breaker on din rail and reattach wiring to bottom of circuit breaker.
24. Reattach left side trim piece and magnetron plenum assembly.
25. Refit top cover and left and right side covers.
26. Plug the oven in and set the temperature to 525 °F and allow the oven to come up to temperature and remain at temperature for 15 minutes.
27. Refer to Chapter 5, and put the oven into test mode. At the bottom left of the screen are the letters P, S, and M. As the oven door is slowly opened, the background of the letters will light up indicating that the switches have opened.
28. Slowly open and close the door to confirm the proper sequence of the switches, P, S, M and M, S, P respectively.
29. If the sequencing is not correct, remove the left and right side covers and adjust the switch brackets as necessary and retest the oven.
30. If the sequencing is correct, while in the test mode refer to section 9-2 and perform the microwave radiation leakage tests.

FINAL TESTING OF DOOR SWITCH ADJUSTMENT:

19. After the door switch assemblies have been properly aligned and adjusted on both sides, confirm that with the door closed that all three switches contacts are closed.

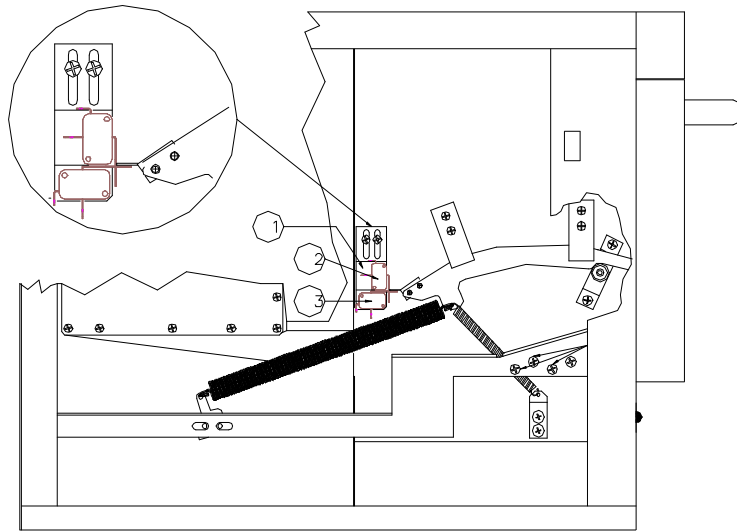

C3/C AND C3/CMULTI OVENS SWITCH CONFIGURATION

1. MONITOR/PRIMARY SWITCH BRACKET
2. INTERLOCK MONITOR SWITCH
3. INTERLOCK PRIMARTY SWITCH

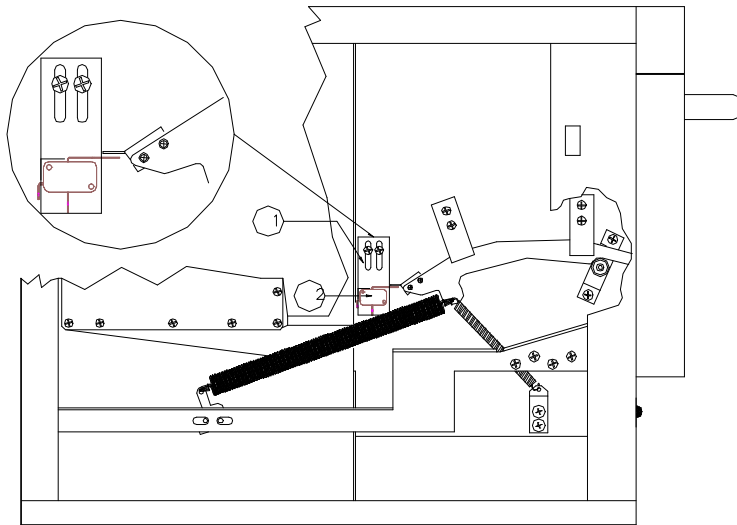

C3, C3/AB AND C3MULTI OVENS SWITCH CONFIGURATION

1. SECONDARY SWITCH BRACKET
2. INTERLOCK SECONDARY SWITCH

C3/AB VS C3/C.WMF

Figure 7-3 Interlock Placement Differences C3/AB vs. C3/C

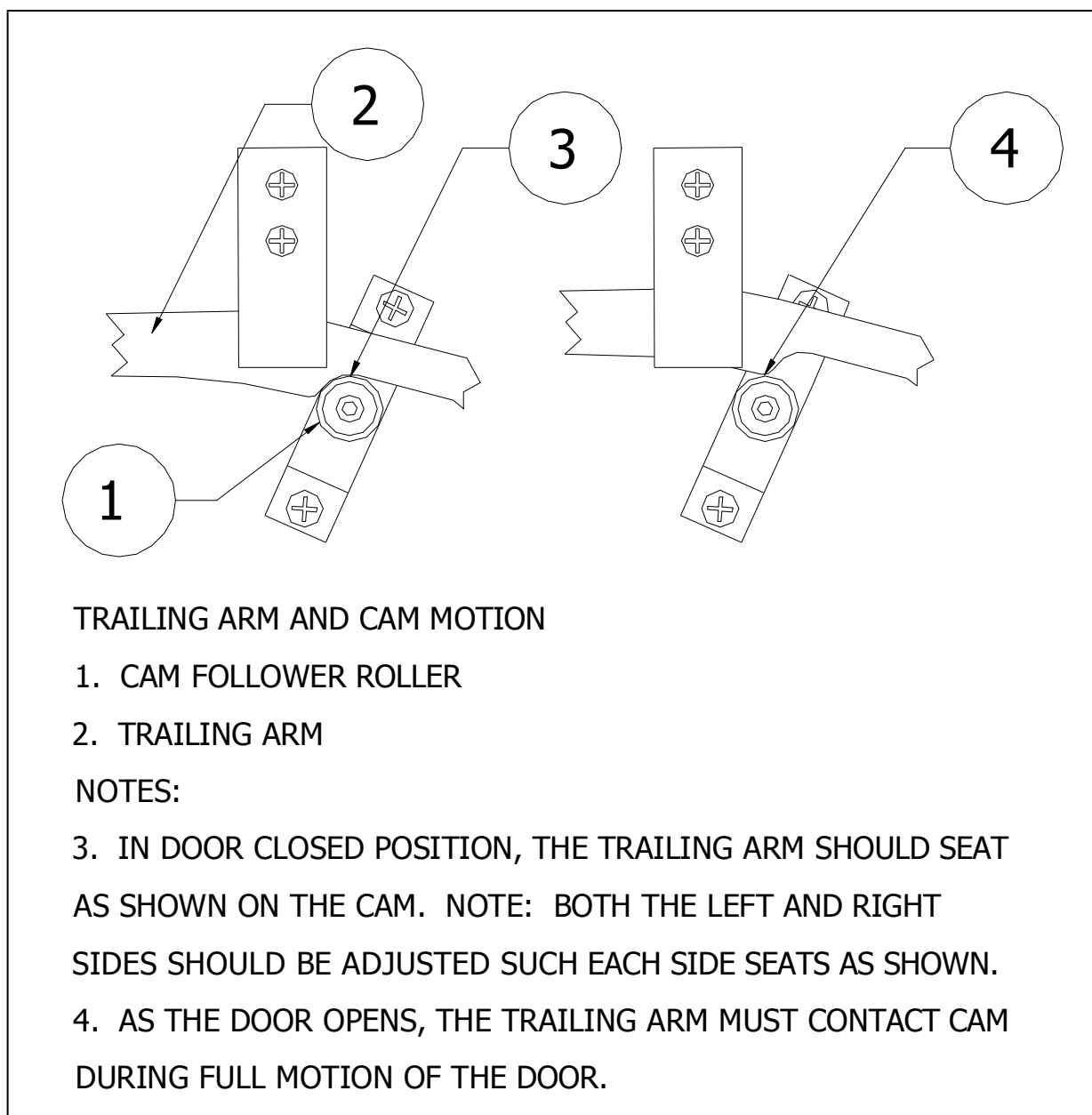

Figure 7-4 Trailing Arm and Cam Motion

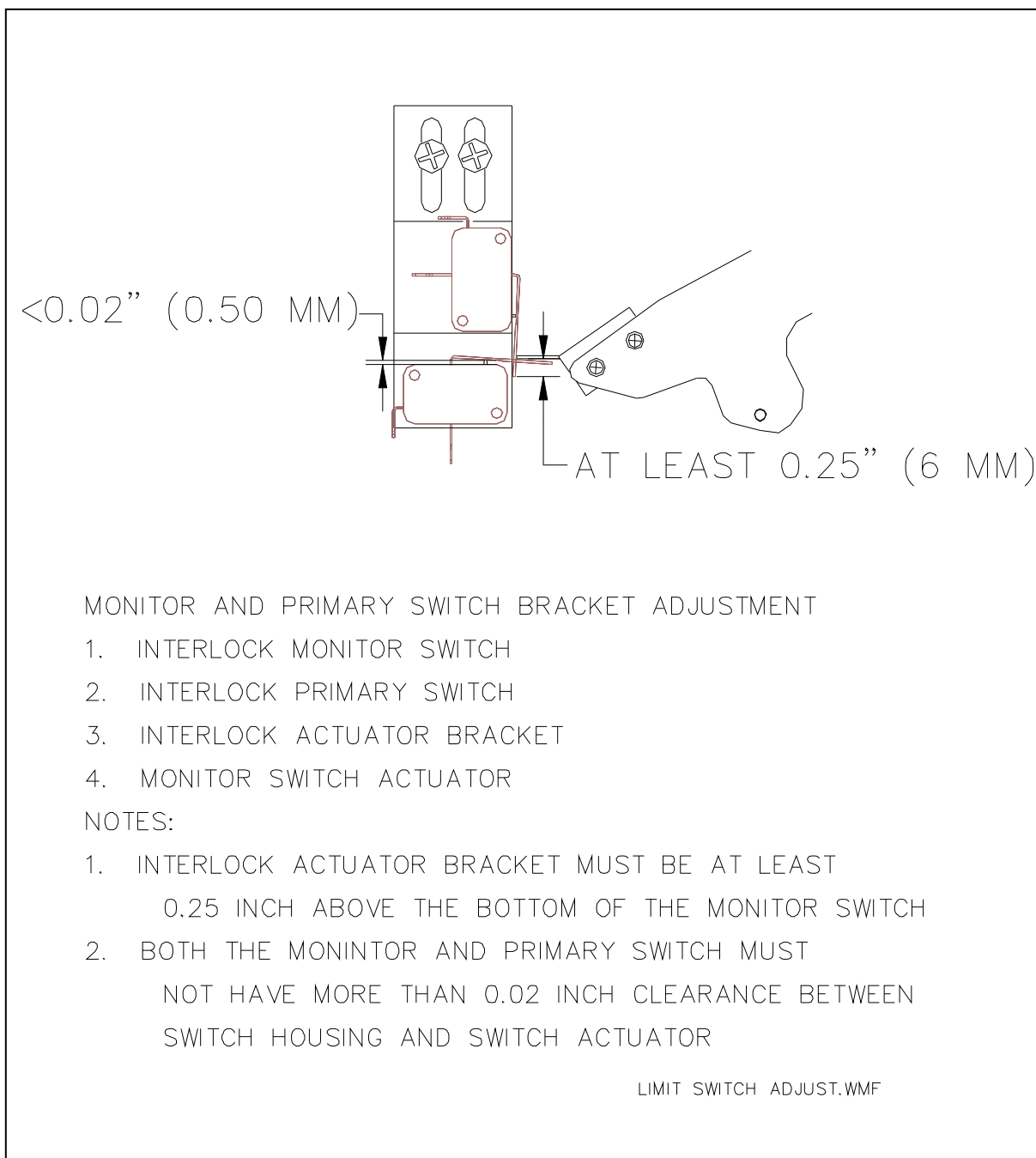

Figure 7-58: Interlock Switch Adjustment

DOOR REMOVAL AND REPLACEMENT

Tools Required:

- 12" long #2 Phillips screw driver
- 3/8" hex driver
- 3/8" socket with 1/4" ratchet wrench
- Set of feeler gages
- Large flat blade screw driver

DOOR REMOVAL

- 1) Remove the side and top panels, top and bottom molding, control panel, and left perimeter trim piece.
- 2) Remove the interlock actuator tabs (#3) and front guide block assembly (#14) from both sides of the oven. (See FIGURE 7-6.)

NOTE: The guide block assembly may or may not contain guide block support shims. Guide block assemblies should be re-installed in the location they were removed from (i.e. right guide block assembly re-installed on right side) to prevent potential trailing arm binding.

- 3) Close the oven door and disconnect the springs (#8 & #15) from both trailing arms (#2).
- 4) Loosen but do not remove the nuts that hold the cam follower assembly (#12) in position, then rotate both assemblies down to vertical orientation.
- 5) Remove the door:
 - a) Remove the four 10–32 (M5) UNF Phillips screws (#11) from the door hinge bar mounting brackets (#7) on both sides of the oven.
 - b) Pull the door away from the oven, bottom first, to slide the hinge bars (#14) out of their slots. Use caution in removing the door to avoid bending the hinge bars. If the bars bind in their slots, gently wiggle the door to free them.
 - c) Remove the door, guiding the hooked portion of the trailing arm over the cam follower rollers (#13).

DOOR INSTALLATION

- 6) Rotate cam follower assembly (#12) down to vertical position to permit the trailing arms (#2) to pass over the cam follower roller (#11) in step 2.
- 7) Assemble the door to the oven:
 - a) Slide the trailing arms through the upper slots and over the rollers.

- b) Slide the hinge bars (not shown) through the lower slots. Use caution in installing the door to avoid bending the hinge bars. If the bars bind in their slots, gently wiggle the door to free them.
 - c) Attach the bars to the door hinge bar mounting brackets (#13) with four 10–32 (M5) UNF screws (#11) on each side (finger tight). Apply 242 thread-locker to screw threads prior to installation.
 - d) Close the door and apply even pressure (approximately 15 to 20 pounds) to the face of the door to squarely seat the door shunt on the oven face. Continue to apply this force while tightening the four screws on each side (two people are recommended).
- 8) Install the springs (#8) on each side between the trailing arm and spring brackets – See door switch adjustment section beginning on page 7-6. Any interference between any other component or wiring and the springs or trailing arms must be corrected before proceeding.
 - 9) Install the front trailing arm guide blocks (#14):
 - a) Assemble (per side) one spacer block, two guide blocks, two spacers, and two screws with lock-washers.

NOTE: The guide block assembly may or may not contain guide block support shims. Guide block assemblies should be re-installed in the location they were removed from (i.e. right guide block assembly re-installed on right side) to prevent potential trailing arm binding

- b) Install one guide block assembly over each trailing arm and tighten screws.
- 10) Install the interlock actuator tabs (#3):
 - a) Open the door.
 - b) Attach the interlock actuator tabs to the trailing arms with two 6–32 UNF (M3) screws, and lock and flat washers on each side.

NOTE: As you face the oven front both actuator tabs are mounted on the inside of the trailing arms.



WARNING!!

At the first closing of the door verify that the actuator tabs do not hit and bend on the trailing arm guides block assemblies (#1 and #14). Verify placement of the actuator tabs to insure that the interlock switch levers do not

bottom out on the switch body (#6). If they do, open the door and realign switch brackets and or actuator tabs again checking for interference with the guide as the door is closed.

DOOR ADJUSTMENT

1) Adjust cam follower assembly (#12) to tension the trailing arms (#2) to apply closing pressure:

- a) Close the door.
- b) Rotate the cam follower assembly so that the top of the trailing arm engages the rear guide (#1) 0.125 inch (+0.125 - 0.031) above the top of the chamfered lead in.
- c) The cam follower assembly roller (#11) should be located on the ramp portion of the trailing arm with 0.020" to 0.050" gap between the top of the roller and the bottom of the trailing arm radius.
- d) Tighten the cam follower bracket nuts.

2) Adjust the interlock switch brackets (#4) and actuator tabs (#3):

NOTE: Refer to page 7-5 for the final door switch adjustment. This adjustment is completed after all door adjustment steps have been completed.

3) Adjust the door pivot position for best alignment by inspecting for the following conditions:

- a) Ideally, the microwave sealing planes (the portions of the oven face and door shunt that overlap each other) should touch, since as the gap between the sealing planes increases, it becomes more likely that the microwave leakage will increase. However, because of manufacturing tolerances, the microwave sealing planes of the door shunt and the oven flange are not perfectly flat. The best door alignment minimizes the gaps between the sealing planes both top and bottom.
- b) If the hinge bars have been pushed too far into their brackets (#13), the lower edge of the sealing planes will be tight and there will be an excessive gap

between the sealing planes along the top edge. In this position, with the top molding removed, most of the hex head of the shunt screws will be seen.

- c) If the hinge bars have not been pushed far enough into their brackets the upper edge of the sealing planes will be tight and an excessive gap will occur between the sealing planes along the bottom edge. This could permit excessive microwave leakage along the bottom edge.

*NOTE: To correct B or C: Loosen the door hinge bar screws (#11) on both sides. Close the door and apply **even** pressure (approximately 15 to 20 pounds) to both sides of the door to squarely seat the door shunt on the oven face. Continue to apply this force while tightening the four screws on each side (two people are recommended).*

- d) By design there is a 0.030" clearance between the Phillips head screws securing the plastic shunt cover and the oven flange on the C3/AB and C3Multi. The C3/C and C3/CMulti gap should be 0.060" (1.50 mm). Verify that one or more of these screws does not contact the oven flange and increase the gap between the sealing planes. This condition may be indicated by the head of the screw(s) marking the oven flange. If this is the case, the door may be warped or the shunt may not be flat. Adjust, repair, or replace the door so that when the door shunt is seated squarely none of the Phillips head screws contact the oven flange.
 - e) Repeat adjustment steps 1 and 2 as required after completing door alignment.
- 4) Adjust the interlock switches per procedure beginning on page 7-6.
- 5) After adjusting the interlock switches the oven must be checked for microwave leakage. Refer to the page 9-2 for instructions and acceptable limits.

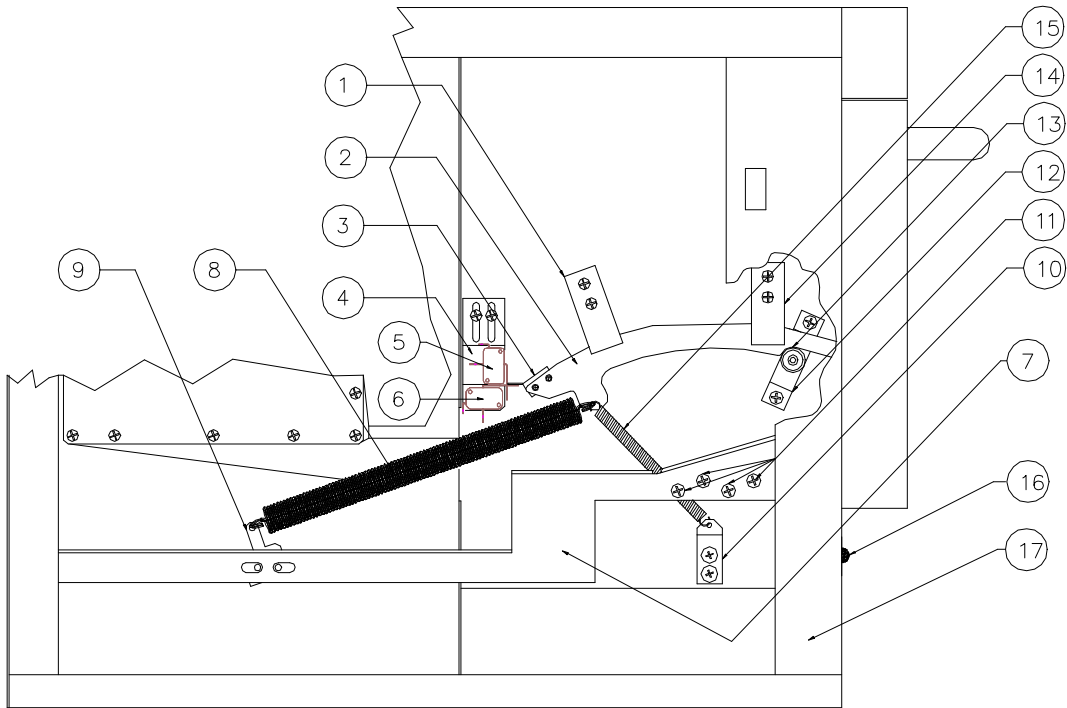

DOOR REMOVAL AND REPLACEMENT (LEFT SIDE)

- | | |
|------------------------------------|---|
| 1. TRAILING ARM GUIDE | 11. 10-32 SCREWS (C3, C3/AB ONLY) |
| 2. TRAILING ARM | M5 (C3/C C3/CMULTI) |
| 3. INTERLOCK ACTUATOR BRACKET | 12. CAM FOLLOWER ASSY |
| 4. INTERLOCK SWITCH BRACKET | 13. CAM FOLLOWER ROLLER |
| 5. INTERLOCK MONITOR SWITCH | 14. GUIDE BLOCK |
| 6. INTERLOCK PRIMARY SWITCH | 15. HELPER SPRING |
| 7. DOOR HINGE BAR MOUNTING BRACKET | 16. SCREW, FRONT TRIM |
| 8. SPRING, TRAILING ARM | (SHOWN WITH FRONT ACCESS PANEL REMOVED) |
| 9. DOOR SPRING BRACKET | 17. FRONT TRIM |
| 10. BRACKET, SPRING, LEFT | |

LEFT SIDE DOOR VIEW.WMF

FIGURE 7 – 6a C3/C & C3/Cmulti (Left Side)

DOOR REMOVAL AND REPLACEMENT PARTS LIST (LEFT SIDE):

See Figure 4-3 & 4-7a.

ITEM	Part Number	Description	Used on Model(s)
1	T0538	TRAILING ARM GUIDE	C3/AB, C3MULTI
1	C0538	TRAILING ARM GUIDE	C3/C, C3/CMULTI
2	T0550	TRAILING ARM, RH	C3/AB, C3MULTI
2	C0550	TRAILING ARM, RH	C3/C, C3/CMULTI
3	T0529	INTERLOCK ACTUATOR BRACKET	C3/AB, C3MULTI
3	C0529-2	INTERLOCK ACTUATOR BRACKET	C3/C, C3/CMULTI
4	T0534	INTERLOCK SWITCH BRACKET	C3/AB, C3MULTI
4	C0534	INTERLOCK SWITCH BRACKET	C3/C, C3/CMULTI
5	T0330	INTERLOCK SECONDARY SWITCH	C3/AB, C3MULTI
5	C0330	INTERLOCK MONITOR SWITCH	C3/C, C3/CMULTI
6	C0330	INTERLOCK PRIMARY SWITCH	C3/C, C3/CMULTI
7	T0516	DOOR HINGE BAR MOUNTING	C3/AB, C3MULTI
7	C0516	DOOR HINGE BAR MOUNTING	C3/C, C3/CMULTI
8	T0542	SPRING, TRAILING ARM	C3/AB, C3MULTI
8	C0542	SPRING, TRAILING ARM	C3/C, C3/CMULTI
9	T0535	DOOR SPRING BRACKET	C3/AB, C3MULTI
9	C0535	DOOR SPRING BRACKET	C3/C, C3/CMULTI
10	TC3-0186	BRACKET, SPRING, LEFT	C3/AB, C3MULTI
10	C0186	BRACKET, SPRING, LEFT	C3/C, C3/CMULTI
11	101450	10-32 X 3/8 PPH CRES	C3/AB, C3MULTI
11	TBD	M5 X 10 mm PPH, CRES	C3/C, C3/CMULTI

DOOR REMOVAL AND REPLACEMENT PARTS LIST (LEFT SIDE) CON'T

See Figure 4-7a.

ITEM	Part Number	Description	Used on Model(s)
12	T0560	CAM FOLLOWER ASSY	C3/AB, C3MULTI
12	C0560	CAM FOLLOWER ASSY	C3/C, C3/CMULTI
13	T0541	CAM FOLLOWER ROLLER	C3/AB, C3MULTI
13	C0541	CAM FOLLOWER ROLLER	C3/C, C3/CMULTI
14	T0548	GUIDE BLOCK	C3/AB, C3MULTI
14	C0548	GUIDE BLOCK	C3/C, C3/CMULTI
15	TC3-0179	HELPER SPRING	C3/AB, C3MULTI
15	C0708	HELPER SPRING	C3/C, C3/CMULTI

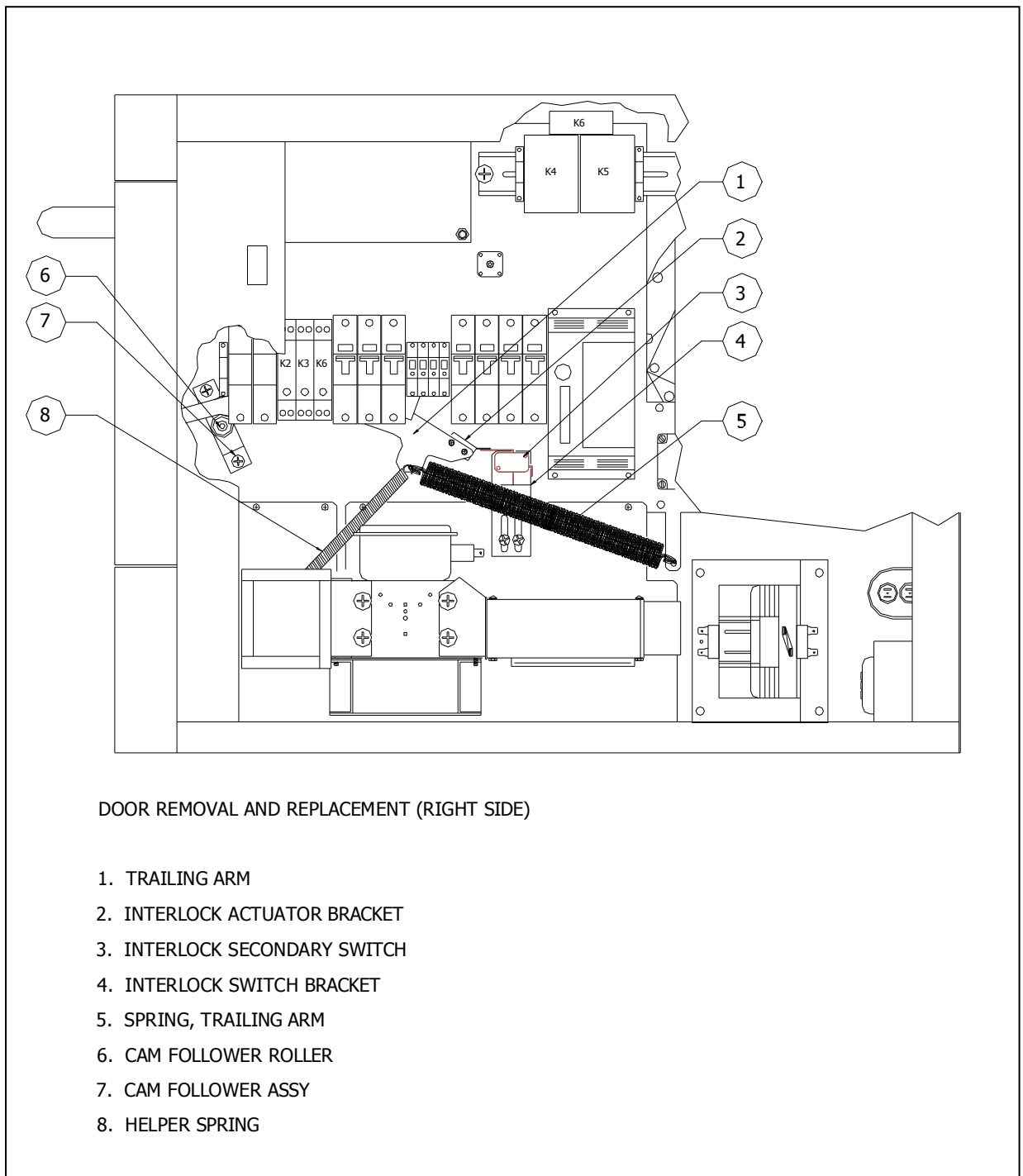

FIGURE 7 – 6b Door Removal and Replacement (Right Side)

DOOR REMOVAL AND REPLACEMENT PARTS LIST (RIGHT SIDE):

See Figure 4-7b

ITEM	Part Number	Description	Used on Model(s)
1	T0550	TRAILING ARM. RH	C3/AB. C3MULTI
1	C0550	TRAILING ARM. RH	C3/C. C3/CMULTI
2	T0529	INTERLOCK ACTUATOR BRACKET	C3/AB. C3MULTI
2	C0529-1	INTERLOCK ACTUATOR BRACKET	C3/C. C3/CMULTI
3	T0330	INTERLOCK MONITOR SWITCH	C3/AB. C3MULTI
3	T0330	INTERLOCK PRIMARY SWITCH	C3/AB. C3MULTI
3	T0330	INTERLOCK SECONDARY SWITCH	C3/C. C3/CMULTI
4	C0534	INTERLOCK SWITCH BRACKET	C3/C. C3/CMULTI
4	T0534	INTERLOCK MONITOR SWITCH BRACKET	C3/AB, C3MULTI
4	T0534	INTERLOCK PRIMARY SWITCH BRACKET	C3/AB, C3MULTI
5	T0542	SPRING. TRAILING ARM	C3/AB. C3MULTI
5	C0542	SPRING. TRAILING ARM	C3/C. C3/CMULTI
6	T0514	CAM FOLLOWER ASSY	C3/AB. C3MULTI
6	C0514	CAM FOLLOWER ASSY	C3/C. C3/CMULTI
7	T0541	CAM FOLLOWER ROLLER	C3/AB. C3MULTI
7	C0541	CAM FOLLOWER ROLLER	C3/C. C3/CMULTI
8	TC3-0179	HELPER SPRING	C3/AB. C3MULTI
8	C0708	HELPER SPRING	C3/C. C3/CMULTI
N/S	T0548	GUIDE BLOCK	C3/AB. C3MULTI
N/S	C0548	GUIDE BLOCK	C3/C. C3/CMULTI
N/S	T0538	TRAILING ARM GUIDE	C3/AB. C3MULTI
N/S	C0538	TRAILING ARM GUIDE	C3/C, C3/CMULTI

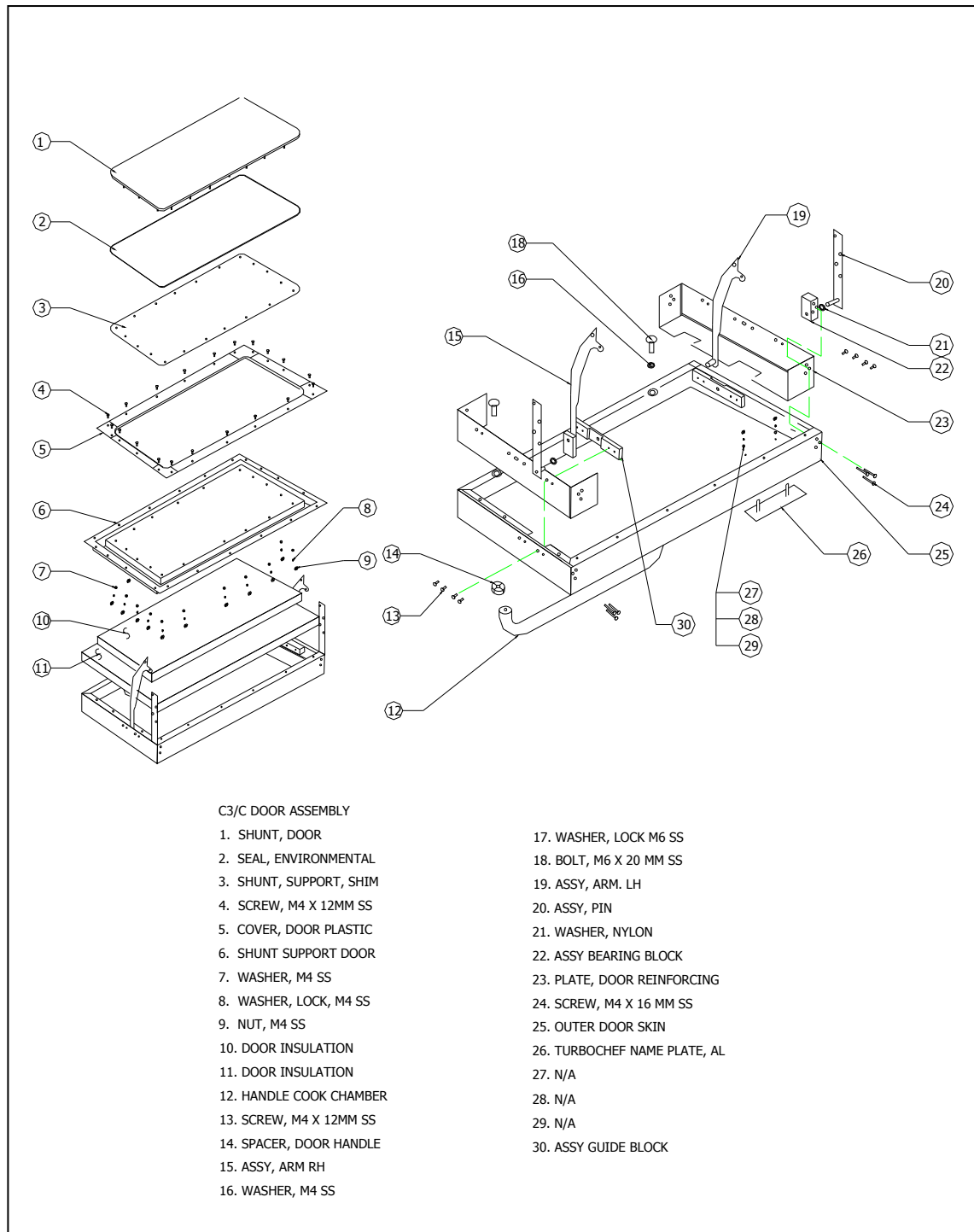

Figure 7-8: C3/C and C3/CMulti Door Assembly

C3/C AND C3/CMULTI DOOR ASSEMBLY PARTS: See Figure 4-8

Item	Part Number	Description	Used on Model(s)
1	C0190	SHUNT, DOOR	C3/C & C3/CMULTI
2	C0325	SEAL, ENVIRONMENTAL	C3/C & C3/CMULTI
3	C0427	SHUNT, SUPPORT, SHIM	C3/C & C3/CMULTI
4	N/A	SCREW, M4 X 12 MM SS	C3/C & C3/CMULTI
5	C0254	COVER, DOOR PLASTIC	C3/C & C3/CMULTI
6	C0426	SHUNT SUPPORT DOOR	C3/C & C3/CMULTI
7	N/A	WAHSER, M4 SS	C3/C & C3/CMULTI
8	N/A	WASHER, LOCK, M4 SS	C3/C & C3/CMULTI
9	N/A	NUT M4 SS	C3/C & C3/CMULTI
10	C0575	DOOR INSULATION	C3/C & C3/CMULTI
11	C0431	DOOR INSULATION	C3/C & C3/CMULTI
12	C0267	HANDLE COOK CHAMBER	C3/C & C3/CMULTI
13	N/A	SCREW, M4 X 12 MM SS	C3/C & C3/CMULTI
14	C0350	SPACER, DOOR HANDLE	C3/C & C3/CMULTI
15	C0500	ASSY, ARM RH	C3/C & C3/CMULTI
16	N/A	WASHER, M4 SS	C3/C & C3/CMULTI
17	N/A	WASHER, LOCK M6 SS	C3/C & C3/CMULTI
18	N/A	BOLT, M6 X 20 MM SS	C3/C & C3/CMULTI
19	C0550	ASSY, ARM, LH	C3/C & C3/CMULTI
20	C0503	ASSY, PIN	C3/C & C3/CMULTI
21	C0504	WASHER, NYLON	C3/C & C3/CMULTI

C3/C AND C3/CMULTI DOOR ASSEMBLY PARTS (CON'T): See Figure 4-8

Item	Part Number	Description	Used on Model(s)
22	C0508	ASSY BEARING BLOCK	C3/C & C3/CMULTI
23	C0507	PLATE, DOOR REINFORCING	C3/C & C3/CMULTI
24	N/A	SCREW, M4 X 16 MM SS	C3/C & C3/CMULTI
25	C0193	OUTER DOOR SKIN	C3/C & C3/CMULTI
26	C0581	TURBOCHEF NAME PLATE, AI	C3/C & C3/CMULTI
30	C0514	ASSY GUIDE BLOCK	C3/C & C3/CMULTI

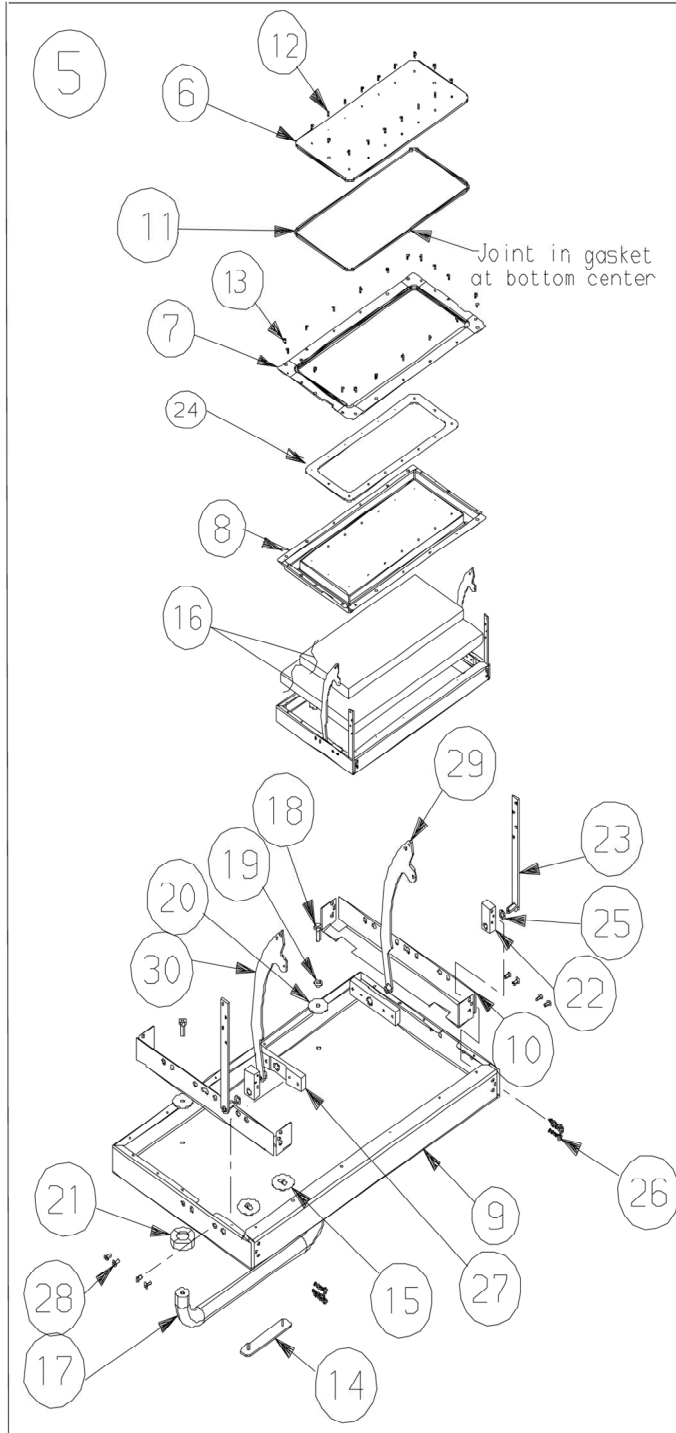

Figure 7-9: C3/AB and C3Multi Door Assembly

C3/AB AND C3MULTI DOOR ASSEMBLY PARTS: See Figure 4-9

Item #	Part Number	Description	Used on Model(s)
6	T0190	SHUNT. DOOR	C3/AB and C3/Multi
7	T0254	PLSTIC COVER. DOOR	C3/AB and C3/Multi
8	T0426	SHUNT SUPPORT DOOR	C3/AB and C3/Multi
9	T0193	OUTER SKIN. DOOR	C3/AB and C3/Multi
10	T0507	PLATE. DOOR REINFORCING	C3/AB and C3/Multi
11	T0325	GASKET. SHUNT	C3/AB and C3/Multi
12	M0999	SCREW. #8-32 X 3/8 SS	C3/AB and C3/Multi
13	R7329	SCREW. TAPPING. #8-32 X 1/2 SS	C3/AB and C3/Multi
14	C0581	NAMEPLATE	C3/AB and C3/Multi
15	NA	NA	C3/AB and C3/Multi
16	T0360	INSULATION KIT	C3/AB and C3/Multi
17	T0267	HANDLE. DOOR	C3/AB and C3/Multi
18	3136	SCREW. CAP 1/4 - 20 X .75 HEX SS	C3/AB and C3/Multi
19	M0417	WASHER. LOCK	C3/AB and C3/Multi
20	T0450	WASHER. FENDER	C3/AB and C3/Multi
21	T0350	SPACER	C3/AB and C3/Multi
22	T0508	BEARING AND BLOCK ASSY	C3/AB and C3/Multi
23	T0503	PIVOT PIN AND BRACKET ASSY	C3/AB and C3/Multi
24	T0427	SHUNT. SUPPORT SHIM	C3/AB and C3/Multi
25	T0504	WASHER. NYLON 5/16	C3/AB and C3/Multi
26	T0505	SCREW. #8-32 X .88 PAN HD SS	C3/AB and C3/Multi
27	T0514	BLOCK ASSY. PIVOT. TRAILING	C3/AB and C3/Multi
28	T0558	SCREW, #8-32 X .38 FLAT HD SS	C3/AB and C3/Multi
29	T0550	TRAILING ARM. ASSY LH	C3/AB and C3/Multi
30	T0500	TRAILING ARM ASSY RH	C3/AB and C3/Multi

CHAPTER 8

CONVECTION CIRCUIT

CATALYTIC CONVERTER

The catalytic converter (See Figure 8-1) is installed in the return air duct behind the heater assembly. The installation of the catalytic converter requires a catalytic converter inner frame to properly position it in the air path.

Due to the nature of most foods and the physics governing the operation of the C3 SERIES oven, grease buildup downstream of the cooking chamber is inevitable. Strict cleaning regiments can solve a majority of the problems, however, recirculation of undiluted greasy saturated air is the main cause of downstream grease accumulation and any associated residual flavors.

The airborne grease tends to collect and bake onto the oven surface downstream of the cooking chamber. This grease, due to the high operating temperatures of the oven, will start to rapidly decompose into derivative organic compounds.

These decompositional derivatives generally have positive and negative effects on cooking; the shorter chain derivatives add favorable flavor characteristics to the food, while the higher order carbon chains lend unpleasant flavor characteristics, such as bitter tarry tastes.

The installation of the catalytic converter greatly effects the grease handling and any residual flavors which might build up over time. A properly operating catalytic converter causes the conversion of airborne grease into water, carbon

dioxide and small amounts of nitrogen and oxygen. The catalytic converter acts as a combustion chamber for the airborne grease. The catalysts present on the filter lowers the ignition temperature of the airborne grease from approximately 700°F (371°C) to 450–550°F (232–288°C), allowing combustion to occur. The operating temperature of the oven directly determines the percentage of airborne grease conversion. A single pass of the air stream yields a 20–30% improvement in air quality.

A problem with the catalytic converter is indicated by a decrease in the effectiveness of browning (caused by a reduction in airflow) or by flavor transfer from one food group to another.

If you suspect the catalytic converter needs cleaning refer to figures on page 8-5 and below. These diagrams provide you with a location reference and exploded view (Note: The Return Air Duct Assembly Panel and the Terminal Heat Shield may be inverted on some C3/AB units. All C3/C units will have this assembly inverted). It is important to carefully remove the insulation and replace it neatly. The metal foil helps shield microwave emissions.

IMPORTANT NOTE:

The catalytic converter can be cleaned with TurboCare® oven cleaner and thoroughly rinsed with DISTILLED water. Let the catalytic converter air dry before reinstalling. IF TurboCare oven cleaner is not available DO NOT SUBSTITUTE-USE DISTILLED WATER.

CONVECTION ELEMENT AND THERMOCOUPLES

The convection element (See Figure 8-1) is located in the rear back on the left side of the oven. It is controlled by one or two solid-state relays (K5 and K7), depending on model, located in the top, center of the control compartment of the oven. Each relay coil operates on 24VDC which is supplied from the I/O control circuit assembly. The temperature is referenced by two "K" type thermocouples.

- The HX thermocouple is in the rear of the oven by the catalytic converter.
- The CC thermocouple is located on the top left side of the oven near the front by the door.

How To Turn Heaters ON and OFF

- 1) Press the BACK key until oven displays says OVEN OFF.
- 2) From the OVEN OFF screen Press the BACK & ENTER keys simultaneously and key in Pin number 9-4-2-8 then ENTER.
- 3) Press the HEATER key and verify that status indicators h and H go from the highlighted position **h H** to the un-highlighted position (this indicates the heater circuit is energized).

On the C3/AB and C3/C, only, one of the heater wires to the hot air element is looped through an inductance coil transformer on the I/O control circuit assembly. It must draw a **minimum** current of 7.5 amps to satisfy the circuit. If it does not, the "H" status character on the Test Mode display will be a reversed character **H**.

- 4) Depress the HEATER key again and the heaters will turn off. Again this is indicated by the status indicators at the bottom of the screen **h H**.

Status Indicators with HEATERS in the OFF mode:

P – S – M – t – **h** – **H** – A – **W**

Status Indicators with HEATERS in the ON mode:

P – S – M – t – h – H – A – **W**

Notes:

In order for the heaters to energize the blower motor must be operational, usually indicated by status indicator A always un-highlighted.

IMPORTANT HEATER DISCUSSION

The C series oven uses either an open coil or sheathed heater. The open coil element is obsolete, but may still be found in C3/AB ovens and C3/C ovens. This heater is susceptible to cleaners not approved by TurboChef. If this heater fails, it should be replaced by the newer sheathed heater (See Figure 8-3).

The sheathed heater consists of two individual heating elements encased within one sheath; therefore, when replacing the single-phase open coil heater with this unit on the C3/AB or C3/C you must wire the individual heaters in parallel. When wired correctly the total resistance should be 12 ohms @ 240VAC (20 Amp draw). At 208 VAC the total resistance should be 9 ohms (23 amps draw).

Changing Heater Operating Voltage

All C3/C factory ovens are equipped with a 208VAC rating heater and set to operate at 208VAC, unless specified. If voltage supplied to oven is 240VAC then change oven setup by following the steps below:

- 1) Press and hold the BACK & ENTER keys simultaneously and then key in 8-6-5-8 (VOLT).
- 2) Press the number 4 to set the oven at 240 then press the number 8 to select the heater rating of 208VAC. A small H will appear next to the OVEN OFF screen.
3. Change wiring on filament transformer to represent supplied voltage.

Pins 1 & 2= 200VAC-208VAC

Pins 1 & 3= 240VAC

Replace the thermocouple as follows:

1. Make a note where the old thermocouple exited the compression fitting.
2. Measure the distance from the exit point to the end of the thermocouple.
3. Mark this distance on your new thermocouple with a marker or a piece of tape.
4. Install the new thermocouple

Heater Circuit Defective Messages

SELF TEST (STEST)	WHILE COOKING (WARMING UP)	CAUSE	CORRECTIVE ACTION
THERMO OPEN	THERMO OPEN	HX Thermocouple amplifier indicates open, (999°)."or" CC Thermocouple amplifier indicates open	<ol style="list-style-type: none"> 1. Check Thermocouple connections on I/O board connector (See I/O board section for details) are not loose or intermittently making contact with mating connector. 2. Replace thermocouple.
HX RISE LOW	HX RISE LOW	<ol style="list-style-type: none"> 1) During the warm up cycle if a 14°F rise is not detected within 5 minutes of initial warm-up, then the controller displays "HX RISE LOW". 2) HX Temperature failed to rise 14°F in 30 seconds during the self-test mode. 	<ol style="list-style-type: none"> 1. Check main internal circuit breaker. If tripped, check the following operation: <ol style="list-style-type: none"> a) Interlock switches (Chapter 7) b) Magnetron transformer (Page 9-8) c) Hi-limit switch (See Figure 8-2) 2. Check heater fuse (F3). If fuse is blown check for short to chassis on all heater wires. 3. Check input current on heater wires. (See Page 8-3) 4. Check operation of the heater relay. (See Page 8-3) 5. Check blower operation (Page 8-9) 6. Check crimp connections on controller. 7. Check HX Thermocouple.
	LOW COOK TMP (F3 LOW TEMP)	CC (Cooking Chamber) temperature has dropped more than 84°F (47°C) or more below cook set point after 5 seconds or more into cook cycle.	<ol style="list-style-type: none"> 1. Check main internal circuit breaker. If tripped, check the following operation: <ol style="list-style-type: none"> a) Interlock switches (Chapter 7) b) Magnetron transformer (Page 9-8) c) Hi-limit switch. See Figure 8-2. 2. Check blower operation. (Chapter 8-9) 3. Check CC Thermocouple circuitry. 4. Check Catalytic Converter (Page 8-2) 5. Check debris catcher (pepperoni catcher). See Figure 8-2 6. Verify cooking chamber top air nozzle holes are not clogged. 7. Open door and run blower from 0% to 100% and verify blower is working properly (Air pressure). 8. Verify oven software is greater than Revision S (C3AD S).

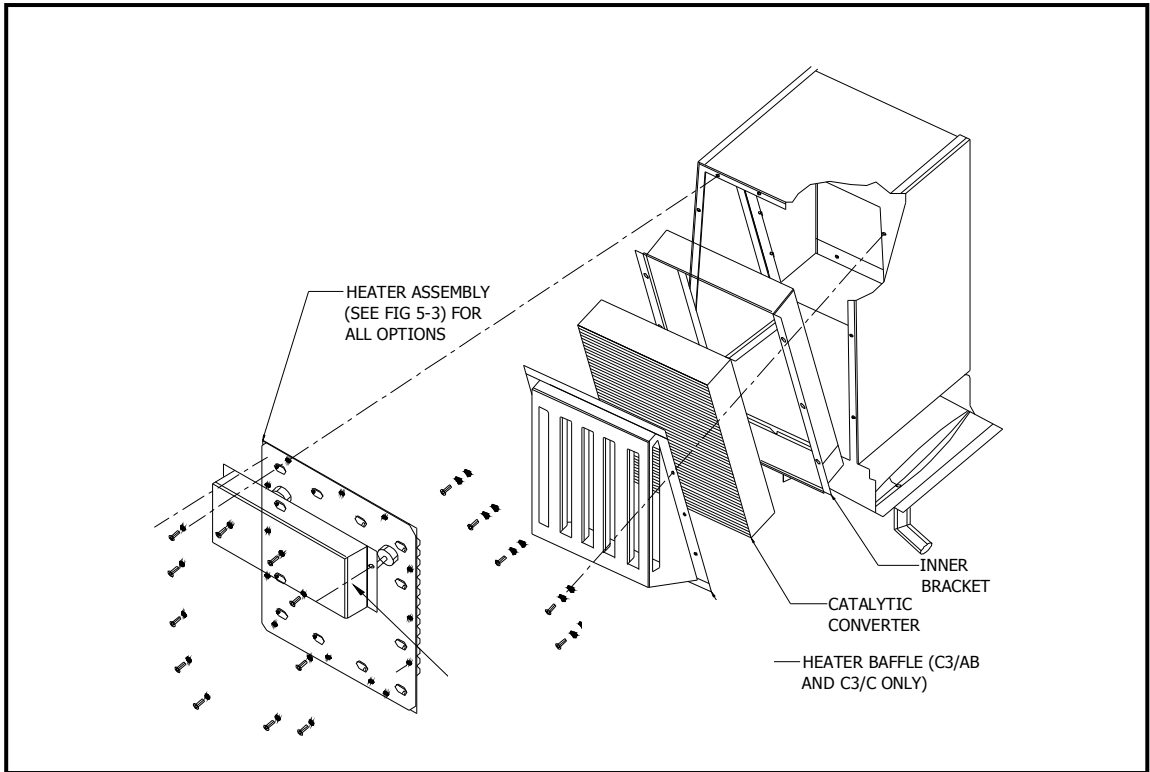

FIGURE 8 - 1 Catalytic Converter Access

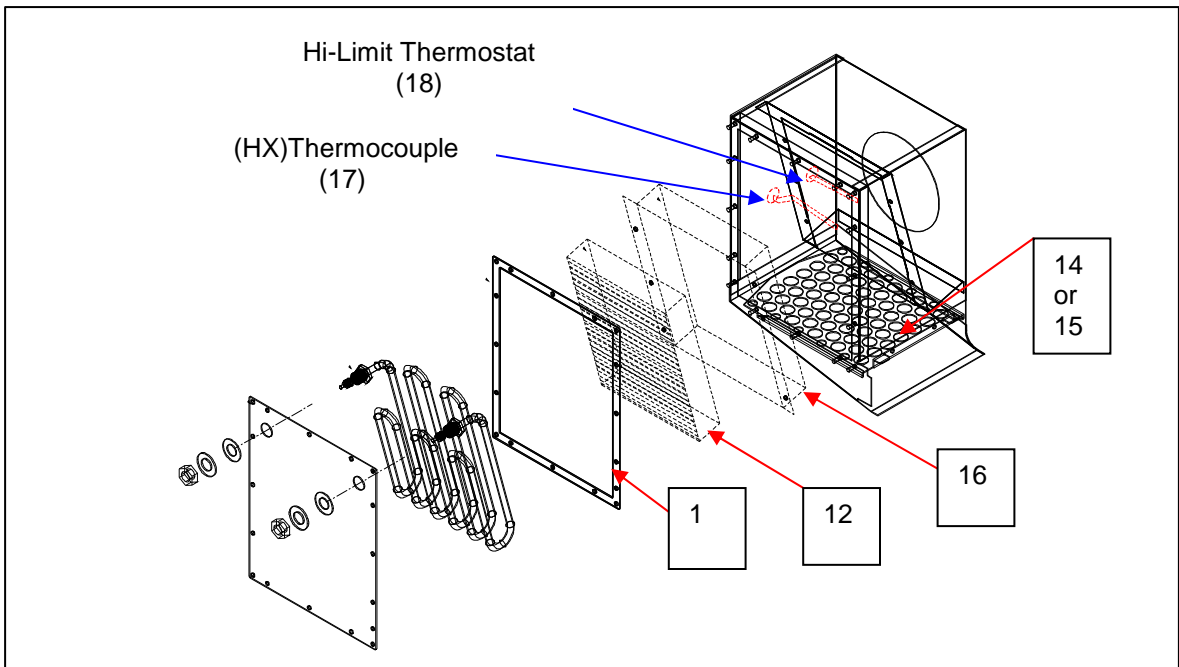

FIGURE 8 - 2 Thermocouple & Thermostat Locations

CONVECTION ELEMENT ASSEMBLIES

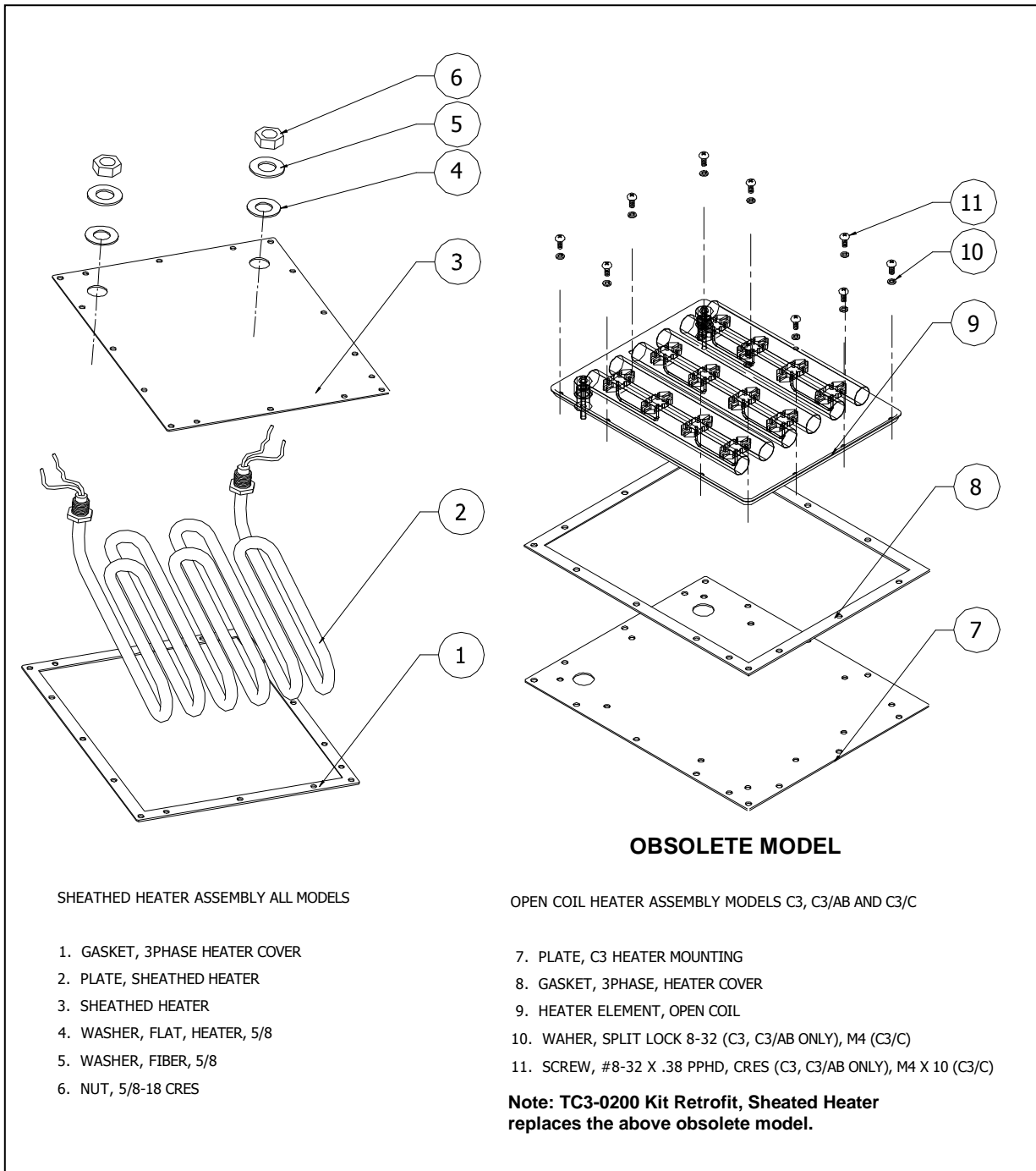

FIGURE 8-3 Convection Heater Assemblies

CONVECTION CIRCUIT PARTS LIST: See Figure 8-3

Item	Part Number	Description	Used on Model(s)
1	TC3-0194	GASKET, 3 PHASE, HEATER COVER	All
2	TC3-0202	PLATE, SHEATHED HEATER	All
3	100652-1	240 VAC SHEATHED HEATER	All (240 VAC)
3	100652-3	208 VAC SHEATHED HEATER	All (208 VAC)
3	100652-3	200 VAC SHEATHED HEATER	All (200 VAC)
4,5,6	NA	SHEATHED HEATER HARDWARE (SUPPLIED W/HEATER)	All
7	TC3-0192	PLATE, C3 HEATER MOUNTING (OBSOLETE)	C3/AB, C3/C
8	TC3-0194	GASKET, 3 PHASE HEATER COVER	All
9	100665	240 VAC HEATER ELEMENT, OPEN COIL (OBSOLETE)	C3/AB, C3/C
9	100666	208 VAC HEATER ELEMENT, OPEN COIL (OBSOLETE)	C3/AB, C3/C
10	102390	WASHER, SPLIT LOCK, #8 CRES	C3/AB
10	102230	WASHER, SPLIT LOCK, M4	C3/C
11	101665	SCREW, #8-32 PPHD, CRES	C3/AB
11	101671	SCREW, M4 X 10 mm	C3/C
12	T0185	CATALYTIC CONVERTER	All
13	100440	BLOWER MOTOR SPEED CONTROLLER (SP200)	All
13	100441	BLOWER MOTOR SPEED CONTROLLER (DELTA)	All
14	T0204	PEPPERONI CATCHER (SMALL HOLE)	C3/AB, C3/C
15	TC3-0197A	PEPPERONI CATCHER (EXPANDED METAL) MUST ONLY BE USED WITH SHEATHED HEATER ASSY	All
16	C0260	BRACKET, CATALYTIC CONVERTER INNER	C3C
17	102065	TYPE K THERMOCOUPLE	All
18	R7603	HI-LIMIT THERMOSTAT	All

Note: When upgrading to a new sheathed heater, order TC3-0200 which includes the following items, 1, 2, 3 (specify voltage), 15. This kit is provided with a step by step field service bulletin FSB10033.doc

CONVECTION (BLOWER) MOTOR OPERATION

The convection (blower) motor is a variable speed convection motor, which operates from zero rpm up to 7000 rpm. The blower motor speed is controlled by a SP200 AC/Delta drive control. The speed of the motor is directly proportional to the applied low voltage to the SP200 AC./Delta drive control from the control circuit card. The blower motor operates during warm up cycle, the normal idle operation (for stabilization of the oven temperatures) and also while in the cooking mode at a set desired speed. Additionally, during the Test mode, which allows the technician to manually operate the blower ON and OFF to change the speed (0% to 100%).

HOW TO TURN THE BLOWER ON

- 1) Press the BACK key until displaying say OVEN OFF.
- 2) From the OVEN OFF screen Press the BACK & ENTER keys simultaneously and key in Pin # 9-4-2-8 then ENTER. Older units Pin# 8-3-1-7
- 3) Press the BLOWER key to increase air speed from 0-100%. Each time the key is pressed and increment of 10% will occur on the air speed.
- 4) Verify status indicator "A" at the bottom of the screen is not highlighted.

P – S – M – t – h – H – A – W
- 5) Verify that the blower motor rotates freely and does not vibrate from imbalance.
- 6) Verify that the blower shaft rotates in the counter-clockwise (CCW) direction when viewing the shaft from the right side of unit.
- 7) While in the TEST mode, Open the cook door and ramp the blower speed from 10-100% and verify air pressure is present from the top of the cooking chamber. If oven is cold then place your hand inside cooking chamber and as you ramp the blower air a substantial difference should be noted.

Checking input voltage at motor controller

- 1) Place Oven in Test Mode.
- 2) Press BLOWER Key and Measure Voltage (DC) between Pin 7 (SP-200) or Pin AVI (Delta) and ground. Reference Table 8.1

SP-200 Pin #	Delta Controller Pin #
3= Functional Loss/Reset	AVI= 0-10VDC SPD CMD
4=Forward Run	M0= FWD Command
7=0 to 10 VDC	M2= Reset
9= Common	GND= Ground
11= 24V Common	RC= 24V Com
12=Running command	RB=Running Command

BLOWER MOTOR RPM-VS-LOW VOLTAGE INPUT TO CONTROLLER

Motor Speed (RPM)	Voltage Measurement (VDC)
0	0.0 (varies from 0 to 0.2)
10	1.0
20	2.0
30	3.0
40	4.0
50	5.0
60	6.0
70	7.0
80	8.0
90	9.0
100	10.0

TABLE 8.1

Blower Circuit Defective Messages

SELF TEST	WHILE COOKING	CAUSE	CORRECTIVE ACTION
BLOWER STATUS or "F1 BLOWER"	BLOWER STATUS or "F1BLOWER"	Blower motor speed controller not returning the "running status command" See status indicator A Note: If the door is opening intermittently, the blower will cease to operate.	1) Verify jumper on P3 of control board is present and placed according to motor controller (see wiring diagram section for details). Pins 1&2=Reliance Controller Pins 2&3=Delta Controller 2) Check Auxillary fuses (refer to schematic) 3) Verify incoming voltage is present on controller input (200-240VAC). 4) Verify status indicator A is not highlighted. (See Page 5-3) 5) Check controller output voltage on motor controller (see Table 8-1) 6) Check fault messages on blower motor speed controller (refer to appropriate controller selection). 7) Check all connections in the blower circuit (ribbon cables, signal wires). 8) Check all interlock switches. 9) Verify motor shaft turns freely, if not then remove motor assembly and inspect wheel.

Blower Motor Controller Fault Codes & Troubleshooting

NOTE: If no fault condition exists, the LED will be green. If a fault condition exists, the LED will flash red when a local keypad is not connected. All faults can be reset by cycling the reset control input, pressing the stop key, or cycling power, except as noted in the Corrective Action column below.

NOTE: To recycle power, disconnect power for a full minute, or until the LED extinguishes, before reapplying power.

Reliance Blower Motor Controller Fault Codes & Troubleshooting

# of LED Flashes	Fault Description	Fault Cause	Corrective Action
2	Control Input	<ul style="list-style-type: none"> • Illegal control input sequence 	<ul style="list-style-type: none"> • 3-wire: Verify Start and Jog inputs are not both ON • 2-wire: Verify that only one input (Forward, Reverse, or Jog) is ON
2	Function Loss	<ul style="list-style-type: none"> • Start attempt while STOP (function loss) input is off 	<ul style="list-style-type: none"> • Verify STOP (function loss) input is ON before attempting to start drive.
3	Under Voltage	<ul style="list-style-type: none"> • Low input line • Temporary loss of input line 	<ul style="list-style-type: none"> • Check input line to verify voltage is within operating specifications
4	Over Voltage	<ul style="list-style-type: none"> • High input line • Decel time too fast • Overhauling load 	<ul style="list-style-type: none"> • Check input line to verify voltage is within operating specifications • Increase decel time
5	Drive Overload	<ul style="list-style-type: none"> • Excessive driven load 	<ul style="list-style-type: none"> • Reduce the load
5	Motor Overload	<ul style="list-style-type: none"> • Excessive driven load 	<ul style="list-style-type: none"> • Verify P-02 is set correctly • Reduce the load. • Check for mechanical binding
6	Over Temperature	<ul style="list-style-type: none"> • Operating environment is too hot • Fan is blocked or not operating • Excessive driven load 	<ul style="list-style-type: none"> • Verify the ambient temperature is <50°C • Verify clearance above/below drive • Check for fan obstruction. Replace if necessary • Reduce the carrier frequency (P-64) • Reduce the load
7	Over Current (300%)	<ul style="list-style-type: none"> • Shaft rotation blocked • Excessive driven load • Output wiring is incorrect or shorted 	<ul style="list-style-type: none"> • Check for obstructions to shaft rotation or reduce excessive load • Increase accel/decel time • Verify output wiring is correct
8	Bad Keypad Connection	<ul style="list-style-type: none"> • Bad connection from keypad to drive 	<ul style="list-style-type: none"> • Verify keypad is properly connected to drive
		<ul style="list-style-type: none"> • 	<ul style="list-style-type: none"> •

TurboChef Technologies, Inc. C Series

# of LED Flashes	Fault Description	Fault Cause	Corrective Action	
9	Negative Slope	<ul style="list-style-type: none"> • Conflicting parameter values 	<ul style="list-style-type: none"> • Adjust values of parameters P-50 through P-54 	
10	Ground Short	<ul style="list-style-type: none"> • Phase U 	<ul style="list-style-type: none"> • Verify output wiring is correct • Verify output phase is not grounded • Verify motor is not damaged 	
		<ul style="list-style-type: none"> • Phase V 		
		<ul style="list-style-type: none"> • Phase W 		
	Phase to Phase Short	<ul style="list-style-type: none"> • Phase U-V 		<ul style="list-style-type: none"> • Verify output wiring is correct • Verify motor is not damaged
		<ul style="list-style-type: none"> • Phase U-W 		
		<ul style="list-style-type: none"> • Phase V-W 		
11	Checksum Failure	<ul style="list-style-type: none"> • Parameter value out of range 	<ul style="list-style-type: none"> • Load default parameter values (P-60=1), then cycle power. If fault persists, replace drive. 	
12	Microprocessor Fault	<ul style="list-style-type: none"> • Internal processor error 	<ul style="list-style-type: none"> • Cycle power. If fault persists, replace drive. 	

TABLE 5 - 2 Reliance Blower Motor Controller Fault Codes & Troubleshooting

Delta Blower Motor Controller Fault Codes & Troubleshooting

Fault Name	Fault Descriptions	Corrective Actions
Oc	The AC drive detects an abnormal increase in current.	<ol style="list-style-type: none"> 1. Check whether the motors horsepower corresponds to the AC drive output power. 2. Check the wiring connections between the AC drive and motor for possible short circuits. 3. Increase the Acceleration time (Pr.1-09, Pr.1-11). 4. Check for possible excessive loading conditions at the motor. 5. If there are any abnormal conditions when operating the AC drive after short-circuit being removed, it should be sent back to manufacturer.
Ou	The AC drive detects that the DC bus voltage has exceeded its maximum allowable value.	<ol style="list-style-type: none"> 1. Check whether the input voltage falls within the rated AC drive input voltage. 2. Check for possible voltage transients. 3. Bus over-voltage may also be caused by motor regeneration. Either increase the decel time or add an optional braking resistor. 4. Check whether the required braking power is within the specified limits.
OH	The AC drive temperature sensor detects excessive heat.	<ol style="list-style-type: none"> 1. Ensure that the ambient temperature falls within the specified temperature range. 2. Make sure that the ventilation holes are not obstructed. 3. Remove any foreign objects on the heatsinks and check for possible dirty heat sink fins. 4. Provide enough spacing for adequate ventilation.
Lu	The AC drive detects that the DC bus voltage has fallen below its minimum value	<ol style="list-style-type: none"> 1. Check whether the input voltage falls within the rated AC drive's input voltage.
OL	<p>The AC drive detects excessive drive output current.</p> <p>Note: The AC drive can withstand up to 150% of the rated current for a maximum of 60 seconds.</p>	<ol style="list-style-type: none"> 1. Check the motor overload (shaft binding). 2. Reduce torque compensation setting as set in Pr.7-02. 3. Increase the AC drive's output capacity.
oLI	Internal electronic overload trip	<ol style="list-style-type: none"> 1. Check for possible motor overload. 2. Check electronic thermal overload setting. 3. Increase motor capacity. 4. Reduce the current level so that the drive output current does not exceed the value set by the Motor Rated current Pr. 7-00
oL2	Motor Overload. Check the parameters settings (Pr.6-03 to Pr. 6-05)	<ol style="list-style-type: none"> 1. Reduce the motor load. 2. Adjust the over-torque detection setting to an appropriate setting.

TurboChef Technologies, Inc. C Series

Delta Blower Motor Controller Fault Codes & Troubleshooting

Fault Name	Fault Descriptions	Corrective Actions
ocA	Over-current during acceleration: 1. Short-circuit at motor output. 2. Torque boost too high. 3. Acceleration time too short. 4. AC drive output capacity is too small.	1. Check for possible poor insulation at the output line. 2. Decrease the torque boost setting in Pr.7-02. 3. Increase the acceleration time. 4. Replace with the AC drive with one that has a higher output capacity (next HP size).
Ocd	Over-current during deceleration: 1. Short-circuit at motor output. 2. Deceleration time too short. 3. AC drive output capacity is too small.	1. Check for possible poor insulation at the output line. 2. Increase the deceleration time. 3. Replace with the AC drive with one
Ocn	Over-current during steady state operation: 1. Short-circuit at motor output. 2. Sudden increase in motor loading. 3. AC drive output capacity is too small.	1. Check for possible poor insulation at the output line. 2. Check for possible motor stall. 3. Replace with the AC drive with one that has a higher output capacity (next HP size).
EF	The external memory IC can not be programmed	1. When the external terminal EF-GND is closed, the output will be turned off. (Under N.O E.F)
cFI	Internal memory IC can not be programmed.	1. Switch off power supply. 2. Check whether the input voltage falls within the rated AC drive input voltage. 3. Switch the AC drive back on.
cF2	Internal memory IC can no be read.	1. Check the connections between the main control board and the power board (internal to motor controller). 2. Reset drive to factory defaults
cF3	Drive's internal circuitry abnormal.	1. Switch off the power supply. 2. Check whether the input voltage falls within the rated AC drive input voltage. Switch on the AC drive.
HPF	Hardware protection failure	1. Return to the factory. Replace controller.
codE	Software protection failure	1. Return to the factory. Replace controller.
cFR	Auto accel/decal failure	1. Do not use the function of auto acceleration/deceleration.
GF	Ground fault: The AC drive output is abnormal. When the output terminal is grounded (short circuit current is 50% more than the AC drive rated current), the AC drive power module may be damaged. The short circuit protection is provided for AC drive protection, not user protection.	Ground fault: 1. Check whether the IGBT power module is damaged. 2. Check for possible poor insulation at the output line.
CEI	Communication Error	1. Check the connections between the AC drive and computer for loose wires. 2. Check if the communication protocol is properly set.
bb	External Base Block. AC drive output is turned off.	1. When the external input terminal (B.B) is active, the AC drive output will be turned off. 2. Disable this connection and the AC drive will begin to work again.

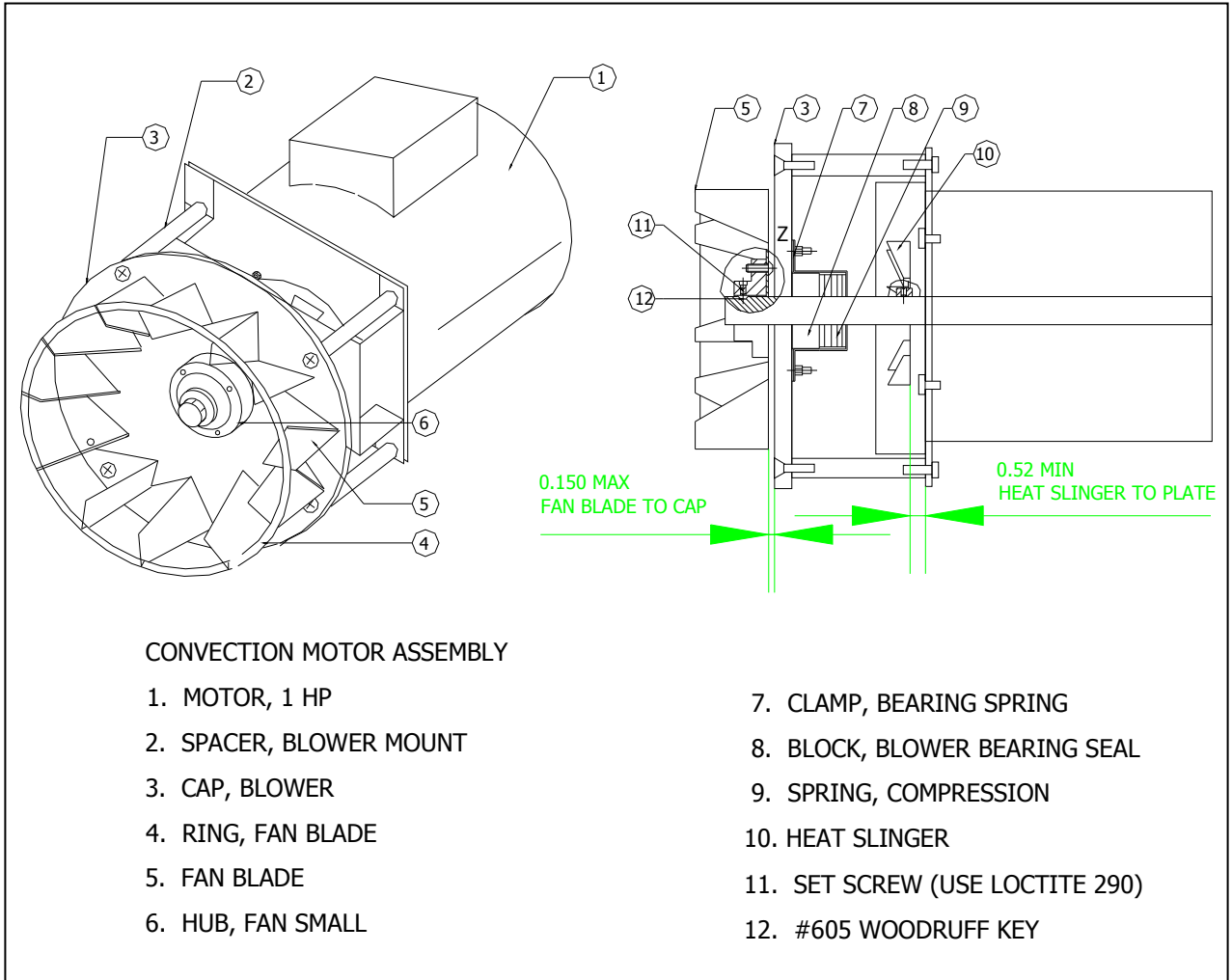

Figure 8-6: Convection Motor Detail PN: C0299

TurboChef Technologies, Inc. C Series

CONVECTION MOTOR PARTS LIST: See Figure 5-6

Item	Part Number	Description	Used on Model(s)
-	C0299	ASSEMBLY, BLOWER MOTOR	All
1	T0076	Motor, 1HP, Mac	All
4	6050070	RING FAN (unwelded)	All
5	6050069	BLADE, FAN (unwelded)	All
4&5	TC3-0214	RING AND FAN TACK WELDED	All
6	7000306-2	HUB, FAN SMALL	C3/AB & C3MULTI
6	C7000306-2	HUB, FAN SMALL	C3/C & C3/CMULTI
7	7001179	CLAMP BEARING SPRING	All
8	700-1177	BLOCK, BLOWER BEARING SEAL	All
9	101733	SRING, COMPRESSION	All
10	102708	HEAT SLINGER	All
11	101715	SET SCREW #8 X 5/16 SS	C3/AB & C3MULTI
11	101722	SET SCREW M4X6 SS	C3/C C3/CMULTI
12	100730	#605 WOODRUFF KEY	All
13	102320	BUTTON HEAD SCREWS	All

Special Kits & Assemblies

Blower Hub Kit P/N: TC3-0238 consists of the following part numbers:

- 1- HUB, FAN SMALL: 700-0306-2
- 4- INTERNAL TOOTH WASHER: 101746
- 2- SET SCREW: 101715
- 4- BUTTON HEAD SCREWS: 102320

Notes:

- When ordering the above kit, request Field Service Bulletin (FSB100037.doc)

This page intentionally left blank.

CHAPTER 9

MICROWAVE CIRCUIT

MEASURING FOR MICROWAVE RADIATION LEAKAGE

The following RF emissions test must be performed every time a service call is done on a C3 SERIES oven. Report your findings on the work order.

The following areas must be measured when performing the RF test.

- Cook Door
- At any place on the outside of the oven (with all covers in place).

Check for microwave leakage as follows:

1. Remove front bottom trim piece.
2. Place a load in the oven for testing. The load must meet the following specifications:
 - A) Load must be 275 ml +/- 15 ml of water.
 - B) The water should be 77± 5°F (25± 3°C).
 - C) The container must be a low form, 600 ml beaker with an inside diameter of approximately 3.35" (8.5cm) and made of an electrically non-conductive material such as glass or plastic.
3. Enter the TEST mode. Refer to page 5-3 for instructions for accessing TEST mode.
4. Position the door leak test tool on the door handle. See FIGURE 9-1 for correct positioning of the leak test tool.
5. Tighten the top screw to slowly open the door. Stop when the control panel indicates that the door switch has disengaged.
6. Loosen the top screw slowly until the control panel indicates that the door switch has engaged.
7. Test for microwave leakage as follows:

This test must be done in conformance with 21 CFR, Chapter 1, Part 1030-Performance Standard for Microwave and Radio Frequency Emitting Product. Part 1030.10 Microwave Ovens. (C) Requirements - (1) Power Density Limit. **"The equivalent plane wave power density existing in the proximity of the external oven surface shall not exceed 1 milliwatt per square centimeter at any point 5 cm or more from the external surface of the oven, measured prior to acquisition by purchaser, and thereafter, 5 milliwatt per square centimeter at any point."**

- A) The tip of the probe should be touching the oven surface being measured with the probe handle perpendicular to the surface.
 - B) Move the probe counterclockwise around the perimeter of the door starting from the upper right corner at a speed of less than 0.5" per second. Be sure to probe entire door perimeter, returning to the upper right corner.
8. Exit the diagnostic mode.
 9. Repeat STEPS 2 and 7 with the cook door closed.



WARNING!!

If the unit fails the radiation test, the oven must be taken out of service immediately until the defect is corrected. In addition, the Code of Federal Regulations 21 Subpart C, 1002.20 requires that leakage readings of over 5 mW/cm² MUST be reported to the manufacturer.

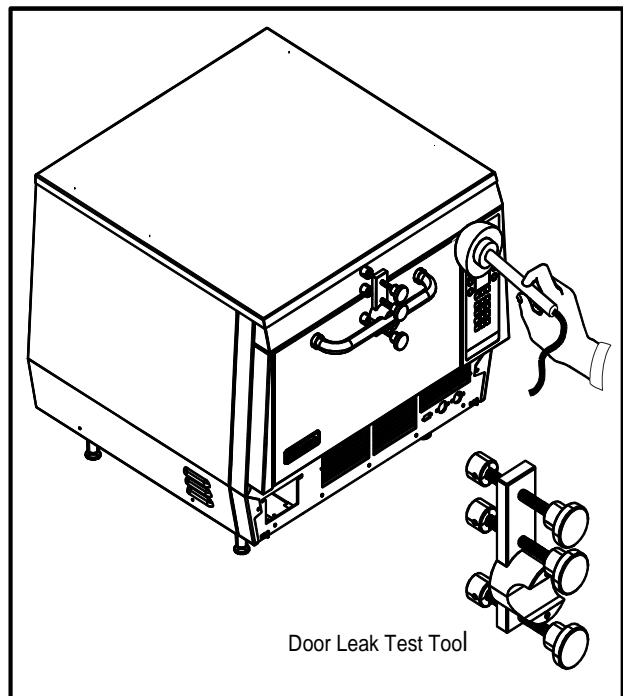

10.

FIGURE 9 - 1 Microwave Leakage Testing

Microwave Circuit Defective Messages

SELF TEST	WHILE COOKING	CAUSE	CORRECTIVE ACTION
<p>LOW MAG CURR *HV BREAKDOWN F3 MAG CURR * European ovens only</p>	<p>LOW MAG CURR *HV BREAKDOWN F3 MAG CURR</p> <p>Note: If this message is detected while cooking it will terminate cook cycle immediately.</p>	<p>Oven CT1 (computer board current sensor) did not detect current to the magnetron transformer.</p> <p>Notes: 1) Magnetron must be ON to detect current in circuit. 2) If main circuit breaker keeps tripping for no apparent reason, check hi-limit switch, monitor relay, heater, mag ssr operation.</p>	<p>1. Check main internal circuit breaker. .If tripped, check the following operation:</p> <ul style="list-style-type: none"> a) Cook Door Switch Misalignment (Chpt. 7) b) Magnetron transformer (Page 9-8) c) Hi limit switch (Page 8-2) d) Heater Failure (Page 8-2) e) Shorted diode <p>2. Check operation of the monitor relay (door operation).</p> <p>3. Check input current to K4-1 wire. Microwave circuit measures approximately 9 Amps. If higher than 15A replace anode transformer (See 9-8).</p> <p>4. Check diode</p> <p>5. Check capacitor</p> <p>6. Check magnetron</p> <p>7. Check ssr operation</p> <p>8. Filament Transformer</p> <p>9. Current Transformer on computer board. See Page 6-10</p>
<p>MAG OVER TEMP F5 MAG TEMP</p>	<p>MAG OVER TEMP F5 MAG TEMP</p> <p>Note: If this message is detected while cooking it will terminate cook cycle immediately</p>	<p>Oven software detected Magnetron thermostat open. Implying the magnetron case temperature is above 212°F (100°C), therefore opening switch and canceling magnetron operation or loose connection.</p>	<p>1. Check Magnetron Thermostat for loose wires.</p> <p>2. Check for proper operation of magnetron blower (Note: Magnetron fan only operates only when magnetron is energized and remains on for 3 minutes after magnetron is turned off).</p> <p>3. Check for loose wiring in the circuit.</p> <p>4. Check magnetron fan relay for proper operation.</p>

MAGNETRON CIRCUIT

Overview of a microwave circuit

The microwave circuit consists of a magnetron and a voltage doubler circuit. The voltage doubler consists of a special step-up transformer, a capacitor, a diode. In addition to the power circuitry in the magnetron the oven utilizes a filament transformer to pre-heat the magnetron filament before applying the high voltage to the anode. As for safety a monitor circuit is used to make the magnetron circuit fail in the failsafe mode.

Monitor Circuit Description:

In addition to the HV circuit, it is imperative to understand how the monitor circuit operates. The Monitor Circuit is a failsafe circuit that is designed to protect the operator if both the Primary and Secondary Interlock Switches fail to operate normally.

The Monitor Circuit consists of the Primary Interlock Switch, Secondary Interlock Switch, Monitor Safety Switch, Monitor Relay and the trip coil on the 35A circuit breaker. When the Cook Door closes during normal operation, the Monitor and Secondary/ Primary Switches close in this order. When all switches are closed, the microwave system is allowed to operate. If during normal operation, either Interlock Switch opens, such as when the Cook Door opens, the Control system will turn OFF the Microwaves; however, if the Monitor Switch opens before both the Primary and Secondary Interlock switches, i.e., abnormal operation, the Monitor switch will de-energize the Monitor Relay. When this occurs, a dead short is placed across L1 and L2. The short then trips the trip coil on the circuit breaker, which permanently interrupts power to the Microwave system until both the Primary and Secondary Interlocks are repaired. See Figure below for a schematic of the monitor circuit.

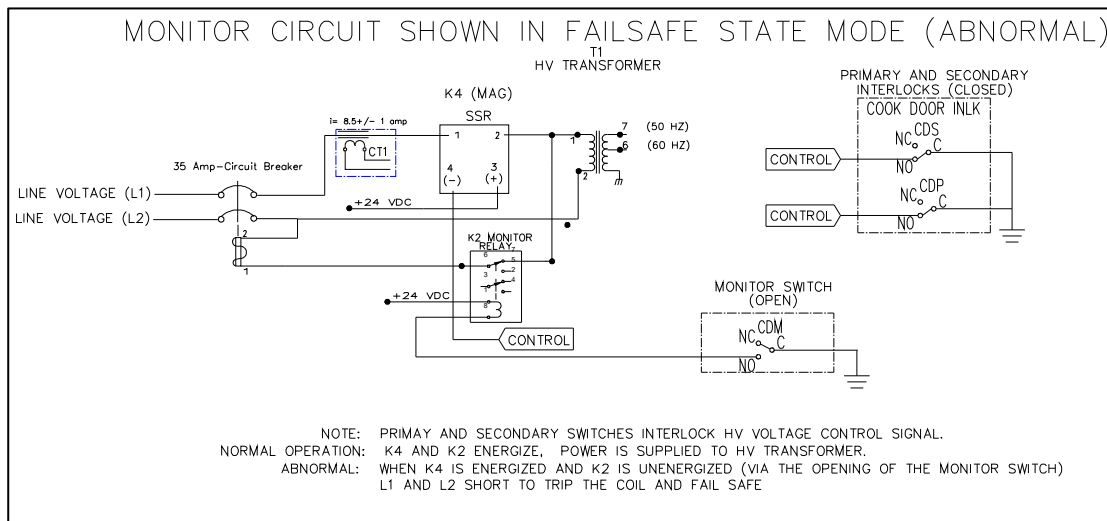

Magnetron High Voltage Transformer (102093)

The magnetron transformer is a ferro-resonant design which limits fault currents and minimizes

magnetron power changes due to input voltage changes. An automatic resetting over-temperature switch is embedded in the high voltage secondary winding and removes power from the primary winding if an over-temperature condition occurs.

In the C3 SERIES a separate transformer is used to preheat the filament for the magnetron for better operation.

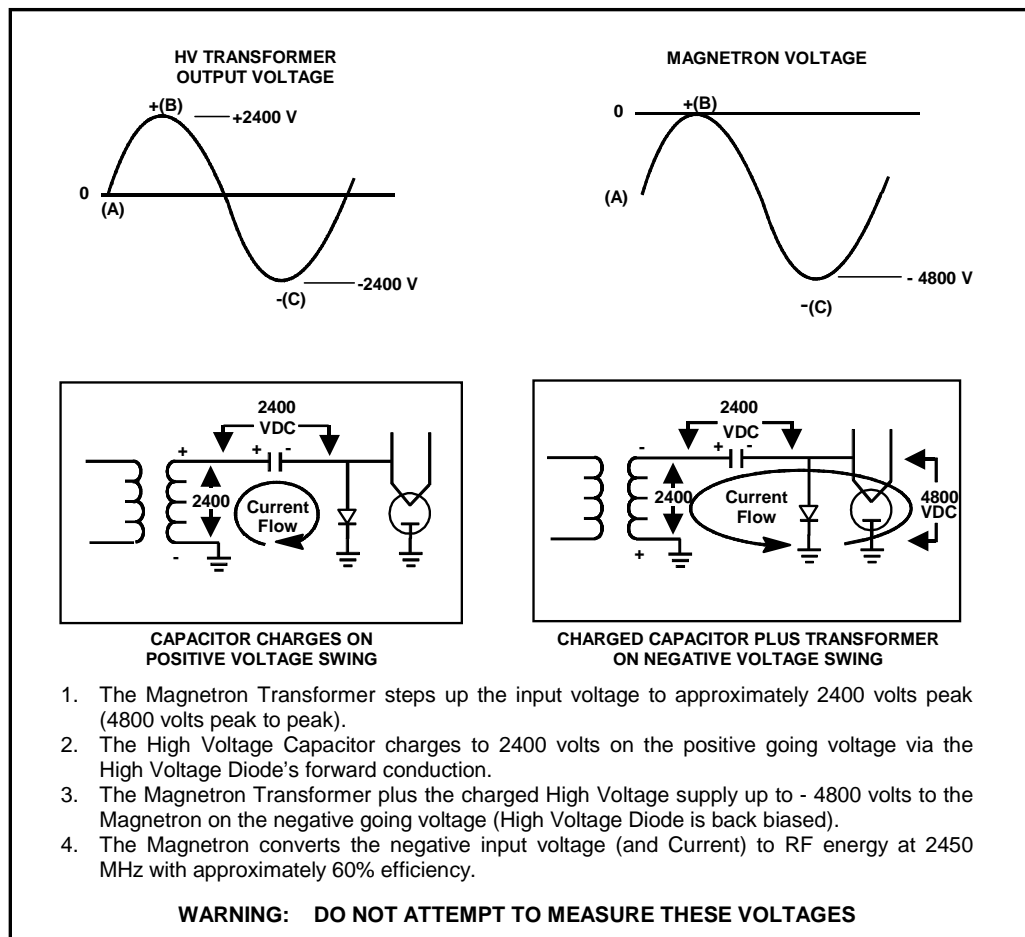

FIGURE 9 - 2 Magnetron High Voltage Power Supply

Filament Transformer(102091)

Background:

The filament transformer is a step down transformer from 208-240VAC to about 4-5VAC. This voltage pre-heats the magnetron filament allowing it to be ready once the magnetron is energized by the high voltage transformer. This method in the industry is known as hot start and highly used to increase the life expectancy of the magnetron.

The filament transformer and stirrer motor are energized by K3 relay when the control signal is grounded at the same time, K1 relay is energized to provide power to the magnetron cooling fan. Both relays, by means of software, will remain in the ON state for 3 minutes after the MAGNETRON circuit has been turned OFF. The typical failure mode of the filament transformer is intermittent operation, meaning that it may not deliver 4-5 volts to the filament of the magnetron, thus not pre-heating the magnetron filament. In this cases the current going to the high voltage transformer may lag. This can result in a "MAG CURR LOW" message.

Step 3: Press and release immediately the MGTRON key and observe the voltage at voltmeter, reading should be around 4.6VAC.



DANGER!!: Do not attempt to measure voltage at pins 4 and 5 of filament transformer without actually isolating it from the high voltage circuit (disconnect anode transformer, capacitor, magnetron and diode). If not isolated the circuit will have a potential of 4800 volts.

Checking the filament transformer



DANGER!! HIGH VOLTAGE

Step 1: Disconnect anode wire from T1 transformer (pin 7 or 6 on transformer) and place circuit breaker in the OFF position; this will isolate the high voltage part of the microwave circuit. Next, disconnect the wires going to the magnetron and connect them to your voltmeter (select AC mode).

Step 2: Place oven in TEST mode. Press BACK key until the oven screen displays " OVEN OFF" then Press and hold the BACK and ENTER keys simultaneously and then key in PIN # 9-4-2-8 (access code) then ENTER. This will allow you to enter into the test mode to manually energize the magnetron.

MAGNETRON TESTING



WARNING!!

The microwave circuit cannot be worked on with the unit on. The unit must be disconnected from the power source. Failure to do so could result in injury or death.



WARNING!!

The HV Capacitor must be discharged before proceeding.

Checking a Magnetron for Open or Shorted Filaments:

1. Disconnect the AC power source and discharge the High Voltage Capacitors.
2. Isolate the magnetron from the circuit by removing the wires from the F and FA terminals.
3. An ohmmeter connected between the filament terminals (F, FA) should indicate a reading of less than 1 Ohm.
4. A continuity check between either filament terminal and the magnetron chassis should indicate an infinite resistance (open).

MAGNETRON REMOVAL AND REPLACEMENT

1. Remove door hinge bar support angle.
2. Remove magnetron cooling fan, duct work and magnetron as an assembly.
3. Unplug and remove magnetron.
4. Install new magnetron.
5. Check the oven for microwave leakage. Refer to page 6-1 for instructions.

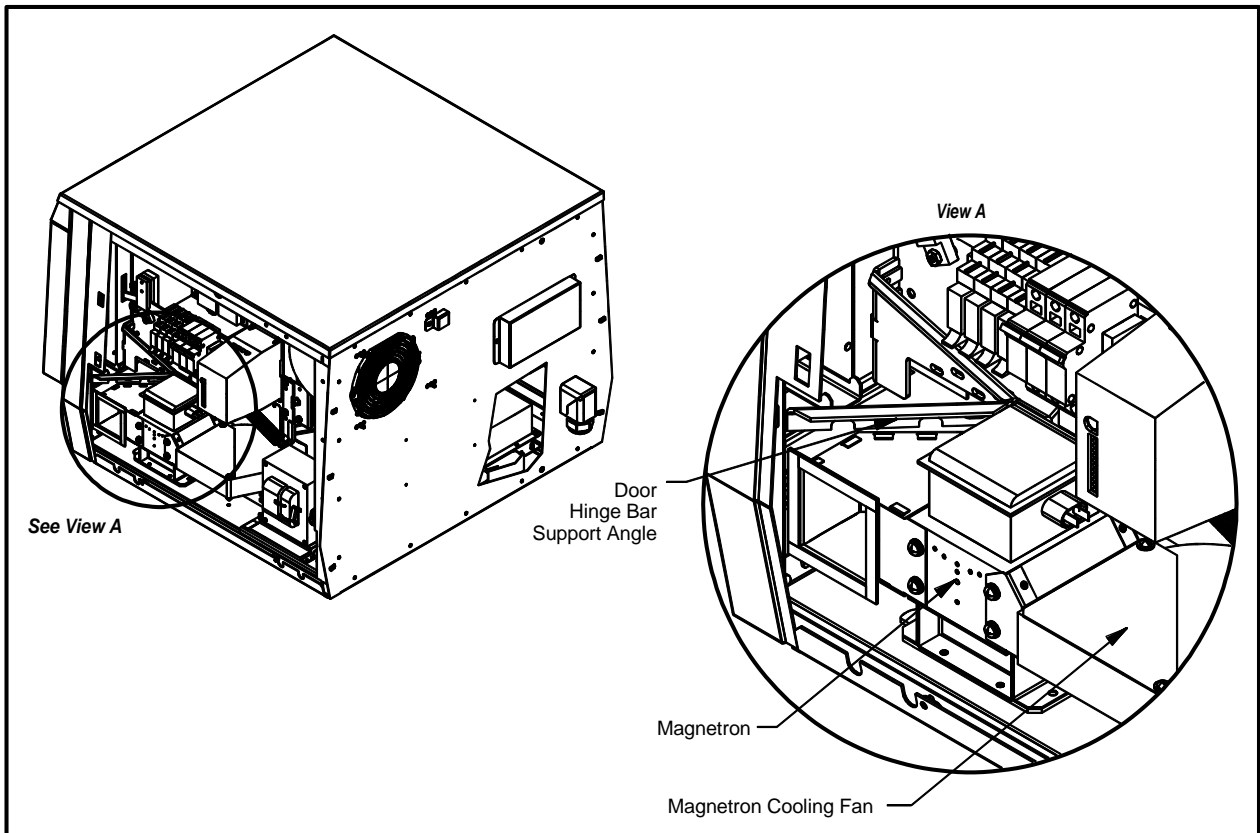

FIGURE 6 - 3 Magnetron Removal and Replacement

COMPONENT TESTING



WARNING!!

The microwave circuit cannot be serviced with the unit on. The unit must be disconnected from the power source. Failure to do so could result in injury or death.



WARNING!!

The HV Capacitor must be discharged before proceeding.



WARNING!!

Do not attempt to measure the magnetron anode or filament voltages. Failure to do so could result in injury or death.

TRANSFORMER TESTING

1. Disconnect the power source and discharge the capacitor.
2. Isolate the transformer from the circuit. (Wires are labeled but remember where they go)
3. Check impedance of the primary and secondary windings. See TABLE 9-1 AND FIGURE 9-4.
4. Filament winding should read less than 0.1 ohms.
5. Reconnect wires.



WARNING!!

When replacing the anode transformer, remove the varnish around the mounting holes to insure proper grounding.

TRANSFORMER SPECIFICATIONS			
Main Transformer (Anode)		Filament Transformer	
Primary DCR	0.58 Ohm.	Primary DCR	(1-2) 23.2 Ohm (1-3) 27.8 Ohm
Secondary DCR:	(5-6) 46.39 Ohm (5-7) 54.00 Ohm	Secondary DCR:	(4-5) .020 Ohm
Input Voltage :	208-240 VAC, 50/60 HZ	Input Voltage :	200-208/240 ± 10%, 50/60 HZ
Input Current:	9.0 Amps RMS	Input Current:	0.42 Amps @ 208 VAC 0.35 Amps @ 240 VAC
Anode Voltage:	2400 VDC Peak @ 0.83 Amps	Filament Voltage:	4.6 VAC @ 14 Amps

TABLE 6 - 1 Transformer Specifications

DIODE TESTING



WARNING!!

DO NOT attempt to measure HV directly.

1. Isolate diode from circuit.
2. Connect the meter leads to the diode terminals.
3. Resistance readings (open) should be indicated in the reverse direction.
4. Resistance readings in the forward direction may be indeterminate due to the number of diodes in series making up this assembly.
5. If there is continuity in both directions (shorted diode).

CAPACITOR TESTING

1. Disconnect the oven from the power source.
2. Isolate the capacitor from the circuit.
3. Fully discharge the capacitor.
4. Connect the ohmmeter between the capacitor terminals. The meter should indicate a low impedance and then slowly return to infinite resistance.
5. Reverse the ohmmeter leads. Repeat step 4.
6. Check each terminal to case. Infinite resistance (open) should be indicated.

TurboChef Technologies, Inc. C Series



WARNING!!

Use extreme caution when taking any current readings. Failure to do so can result in death or serious injury.

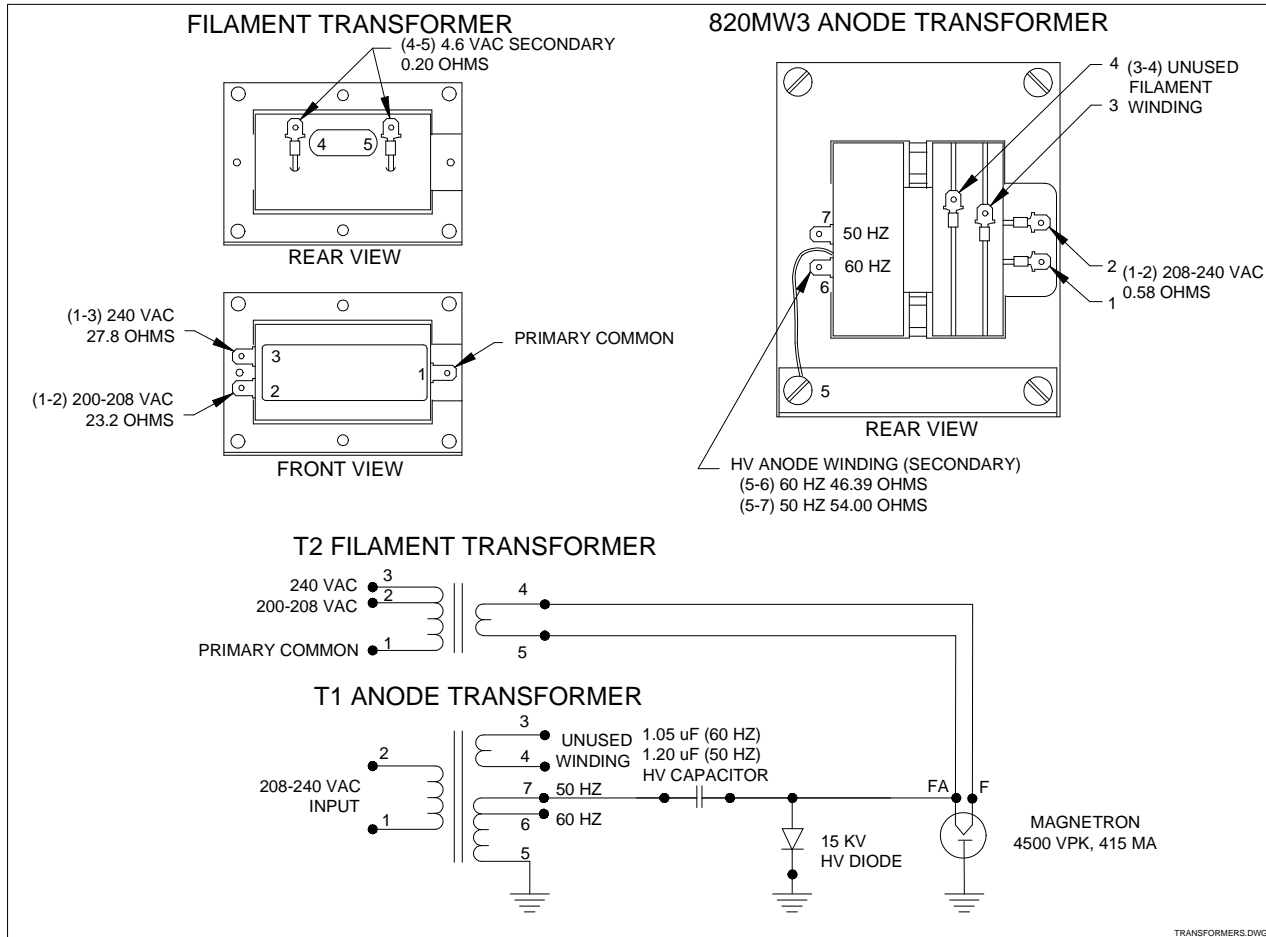

FIGURE 9-4 Transformer Testing

Waveguide Components:

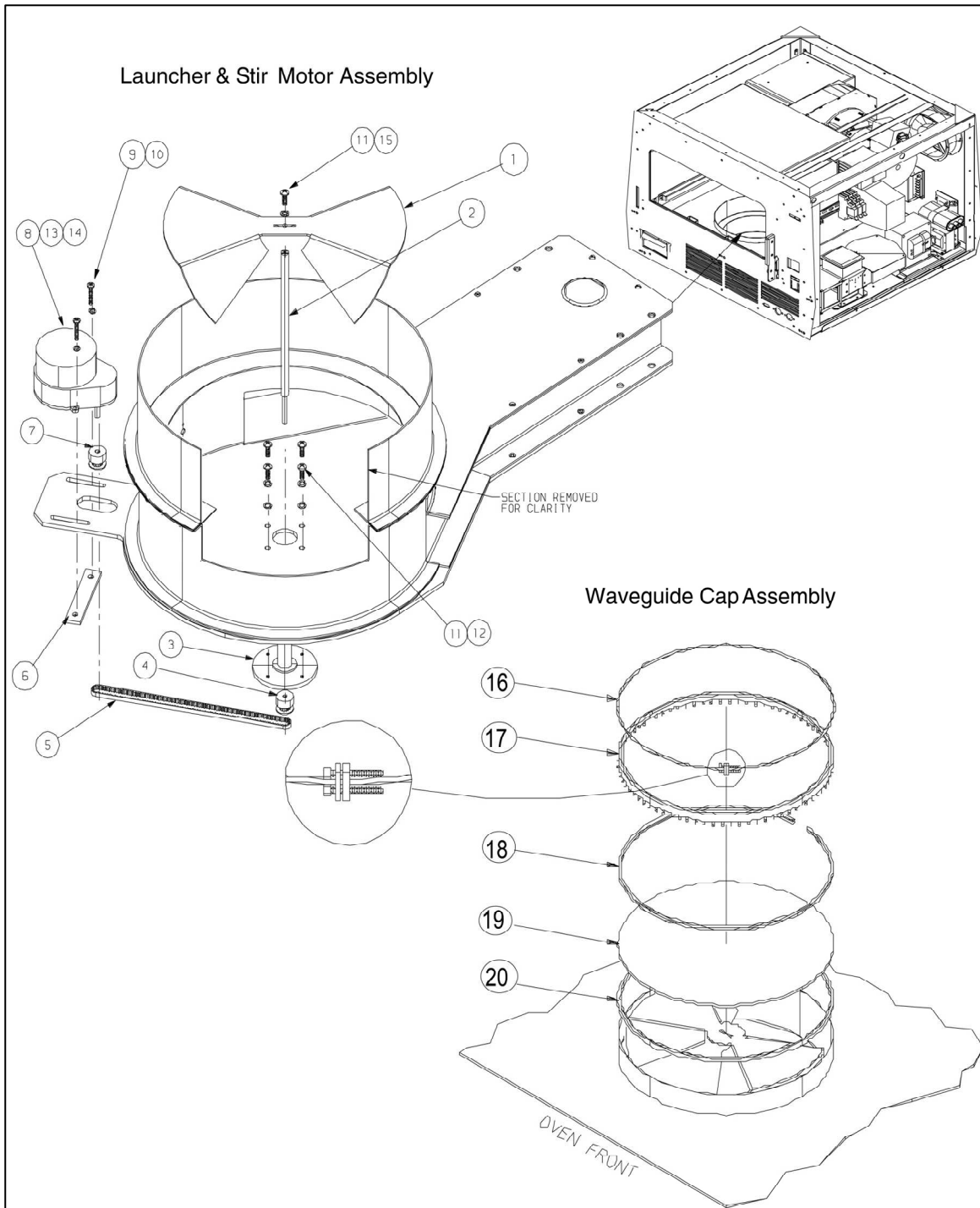

Figure 9-6: Waveguide Assy

Microwave Circuit

WAVEGUIDE COMPONENTS PARTS LIST: See Figure 9-6

Item #	Part Number	Description	Used on Model(s)
1	T0266	BLADE, STIRRER	ALL
2	T0289	SHAFT, STIRRER	C3/AB, C3MULTI
2	C0289	SHAFT, STIRRER	C3/C, C3/CMULTI
3	T0290	HUB, STIRRER SHAFT	C3/AB, C3MULTI
3	C0290	HUB, STIRRER SHAFT	C3/C, C3/CMULTI
4	T0282	SPROCKET, STIRRER SHAFT, .125 BORE	All
5	T0284	BELT, STIRRER MOTOR	All
6	T0397	MOUNTING PLATE, STIR MOTOR	C3/AB, C3MULTI
6	C0391	MOUNTING PLATE, STIR MOTOR	C3/C, C3/CMULTI
7	T0283	SPROCKET, MOTOR, 4MM BORE	All
8	100891	MOTOR, 6 RPM	All
9	101550	SCREW, 4-40 X 5/8 PPH SS	C3/AB, C3MULTI
9	TBD	SCREW, M3 x 12 mm SS	C3/C, C3/CMULTI
10	102370	WASHER, SPLIT LOCK #4 SS	C3/AB, C3MULTI
10	TBD	WASHER, SPLIT LOCK M4 SS	C3/C, C3/CMULTI
11	101590	SCREW, 6-32 X 3/8 PPH SS	C3/AB, C3MULTI
11	TBD	SCREW, M4 x 8 MM SS	C3/C, C3/CMULTI
12	102380	WASHER, SPLIT LOCK #6 SS	C3/AB, C3MULTI
12	TBD	WASHER, SPLIT LOCK M4	C3/C, C3/CMULTI
13	102035	PIN CONNECTOR	C3/AB, C3MULTI
14	102716	CONNECTOR HOUSING	C3/AB, C3MULTI
15	102270	WASHER, INTERNAL LOCK, #6 SS	C3/AB, C3MULTI

WAVEGUIDE COMPONENTS PARTS LIST (con't): See Figure 9-6

Item #	Part Number	Description	Used on Model(s)
15	TBD	WASHER, INTERNAL, LOCK, M4 SS	C3/C, C3/CMULTI
16	700-1339-1	CLAMP, WAVEGUIDE, SINGLE WIRE	C3/AB, C3MULTI
16	C700-1339-1	CLAMP, WAVEGUIDE, SINGLE WIRE	C3/C, C3/CMULTI
17	700-1321	SEAL, RING WAVEGUIDE	C3/C, C3/CMULTI
18	102650	WAVE, SPRING WASHER	All
19	700-1213	PLUG, WAVEGUIDE, QUARTZ	All
20	700-1333	SEAL, PLUG TEFLON	All
NS	100480	HV Diode	All
NS	100206	HV, Capacitor, 2500 V	All
NS	102091	Filament Transformer	All
NS	102093	Magnetron Transformer T1	All

CHAPTER 10

I/O Board & Schematics

TurboChef Technologies, Inc. C Series

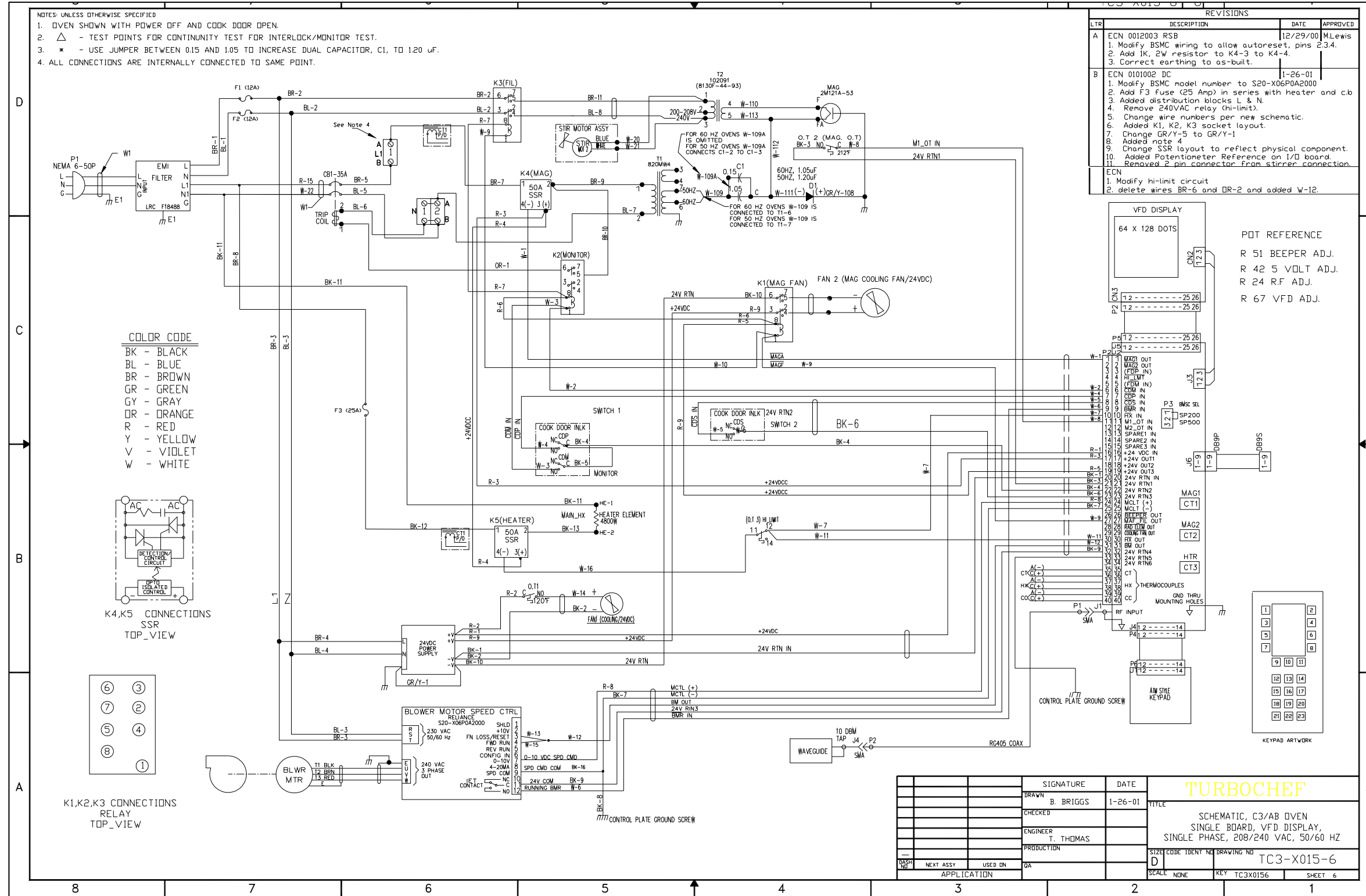

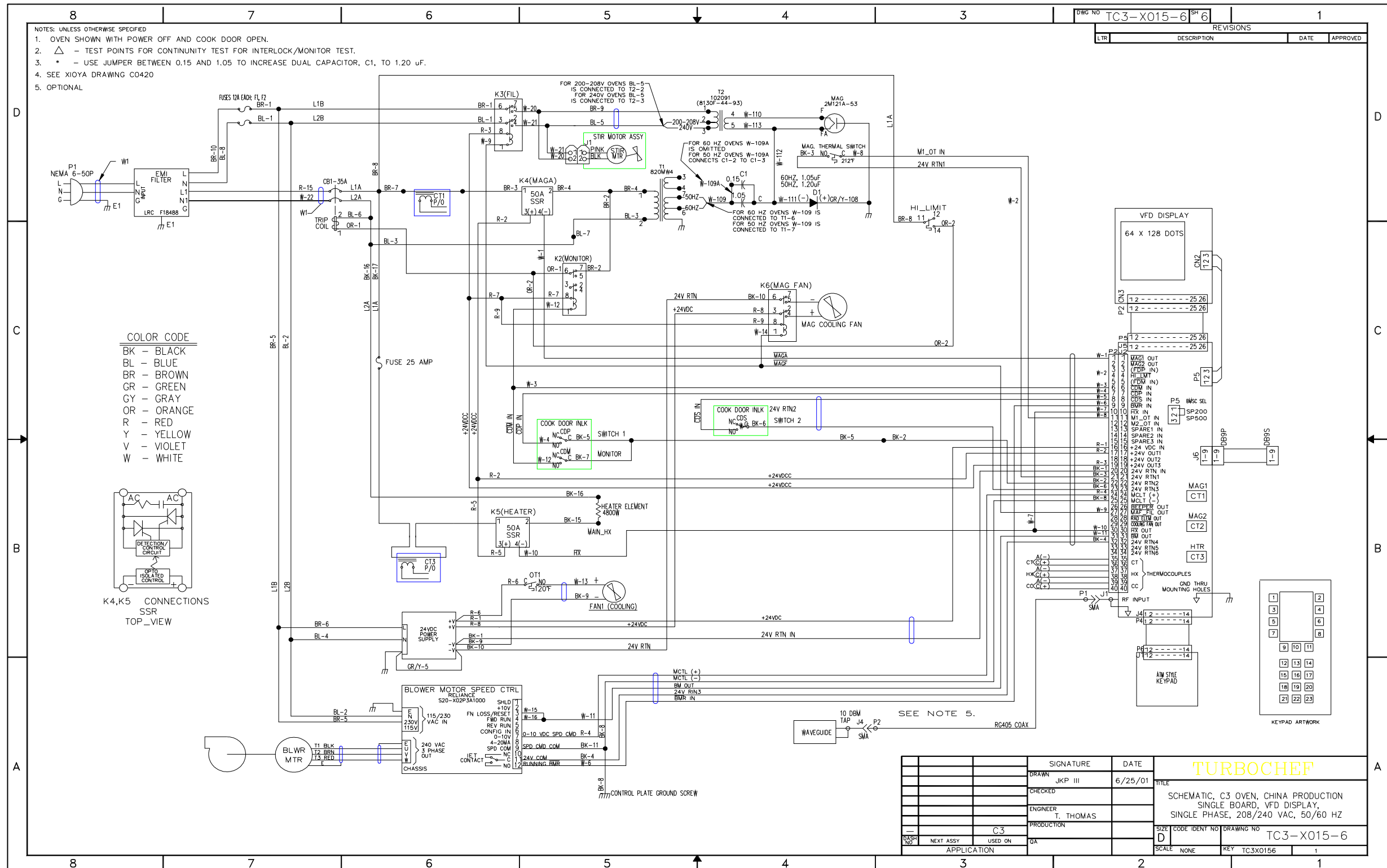

TurboChef Technologies, Inc. C Series

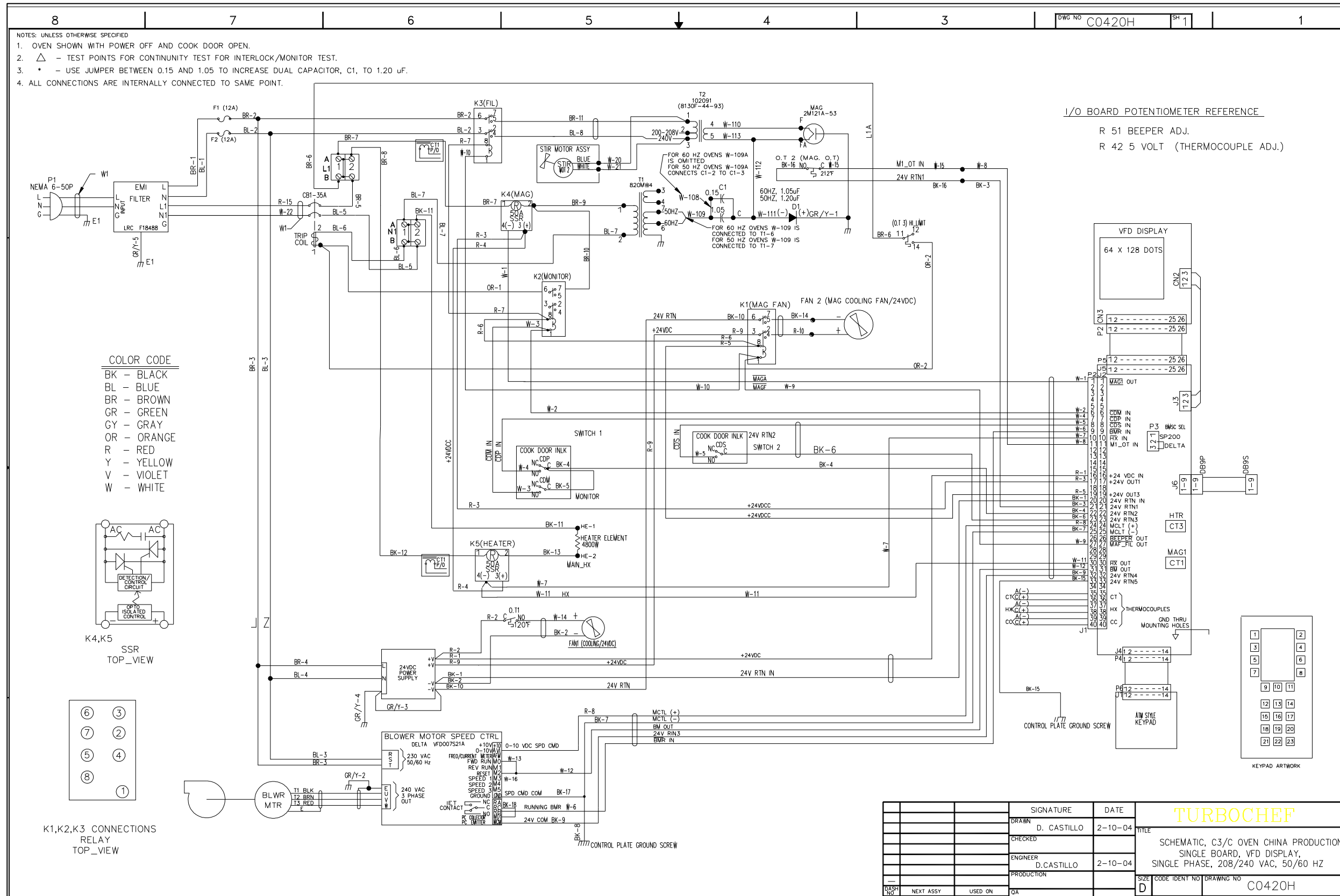

NOTES: UNLESS OTHERWISE SPECIFIED

- OVEN SHOWN WITH POWER OFF AND COOK DOOR OPEN.
- △ - TEST POINTS FOR CONTINUITY TEST FOR INTERLOCK/MONITOR TEST.
- * - USE JUMPER BETWEEN 0.15 AND 1.05 TO INCREASE DUAL CAPACITOR, C1, TO 1.20 uF.

COLOR CODE

- BK - BLACK
- BL - BLUE
- BR - BROWN
- GR - GREEN
- GY - GRAY
- OR - ORANGE
- R - RED
- Y - YELLOW
- V - VIOLET
- W - WHITE

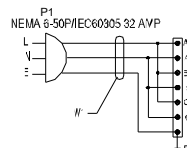

208-240 VAC SINGLE PHASE

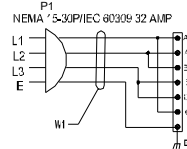

208-240 VAC 3 PHASE DELTA

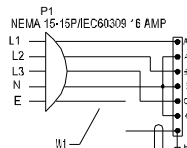

380V-415 VAC 3 PHASE WYE

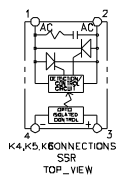

K4, K5, K6 CONNECTIONS SSR TOP VIEW

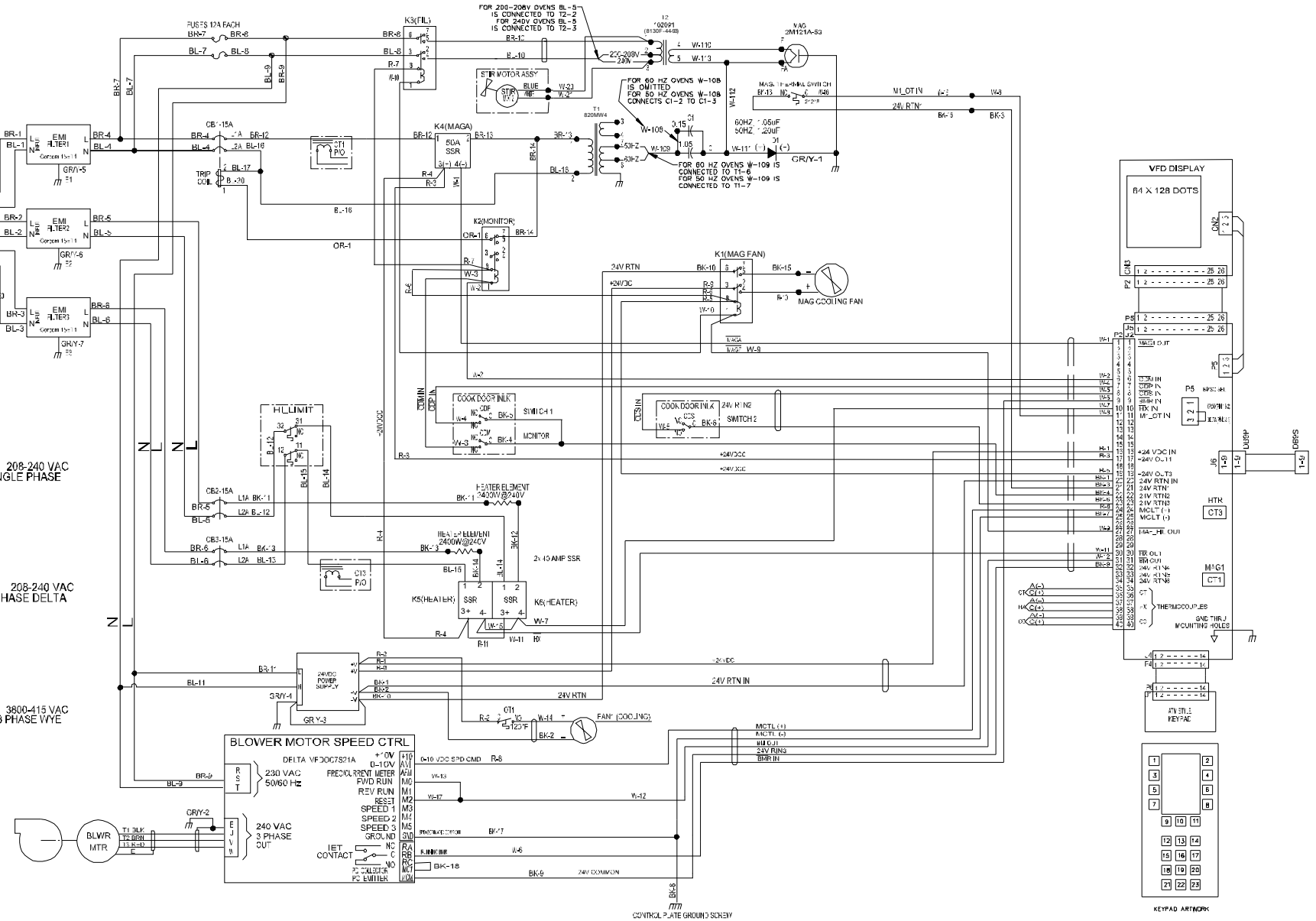

CONTROL PLATE GROUND SCHEMATIC

REVISIONS			
LTR	DESCRIPTION	DATE	APPROVED

QTY	ITEM NO	PART OR IDENTIFYING NUMBER	NOMENCLATURE OR DESCRIPTION	NOTES
MATERIAL: UNLESS OTHERWISE SPECIFIED DIMENSIONS ARE IN INCHES DIMENSIONS INCLUDE FINISH				
FINISH: TOLERANCES: ANGLES ± 1° 2 PLACE DECIMALS ± .02 3 PLACE DECIMALS ± .010				
TC3-0215 REMOVE BURRS & SHARP EDGES HOLE TOL PER ANSI/ASME Y14.5 PARENTHETICAL INFO REF ONLY DO NOT SCALE DRAWINGS				
APPLICATION		PARTS LIST		
		SIGNATURE	DATE	
		DRAWN David Castillo	2-10-04	
		CHECKED		
		ENGINEER		
		PRODUCTION		TITLE SCHEMATIC, C3/C MULTI 208/240 OR 380-415, 1 OR 3 PHASE, 50/60HZ
		DA		SCALE none KEY X SHEET 1 OF 1

TurboChef Technologies, Inc. C Series

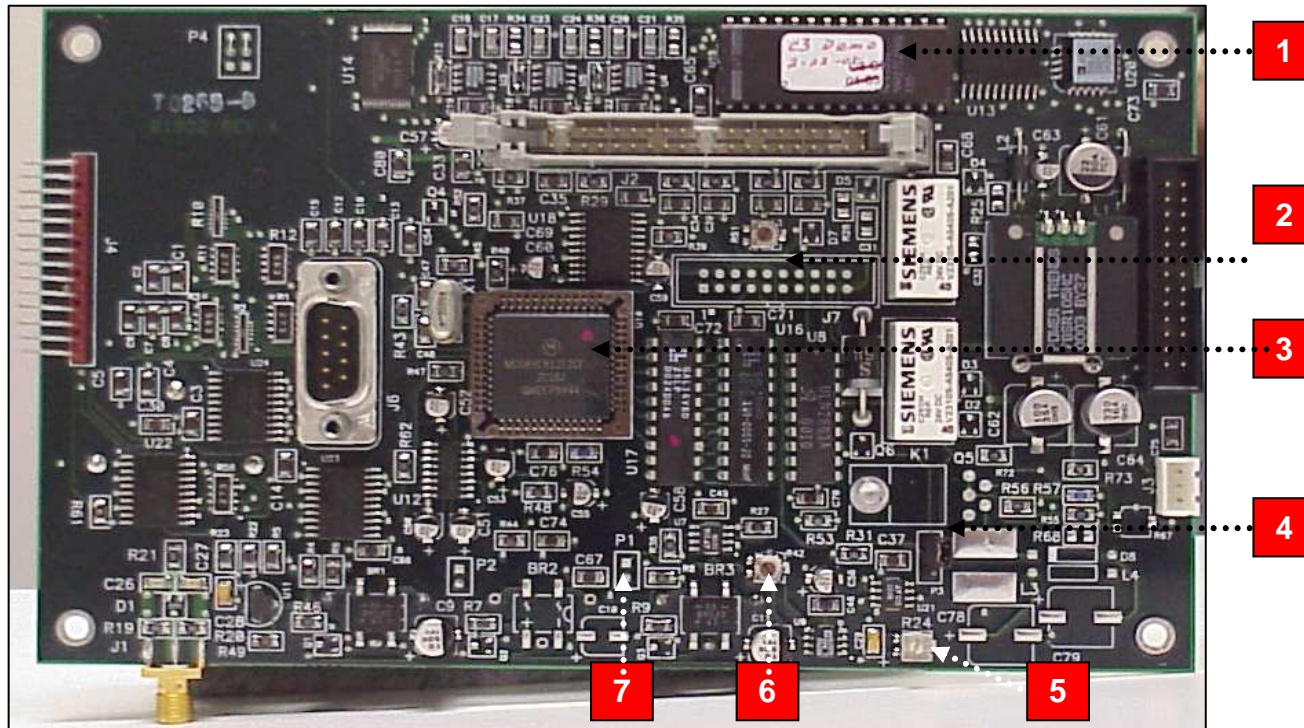

- 1- Software EPROM
- 2- R51 Beeper Volume Adjustment
- 3- Microprocessor
- 4- P3- Blower Motor Controller Mode Selector SP200=1&2
- 5- R24- RF Fluctuation Adjustment (Optional)
- 6- R42- 5 Volt Reference Adjustment
- 7- P1 +5VDC Reference Point

Microwave Circuit

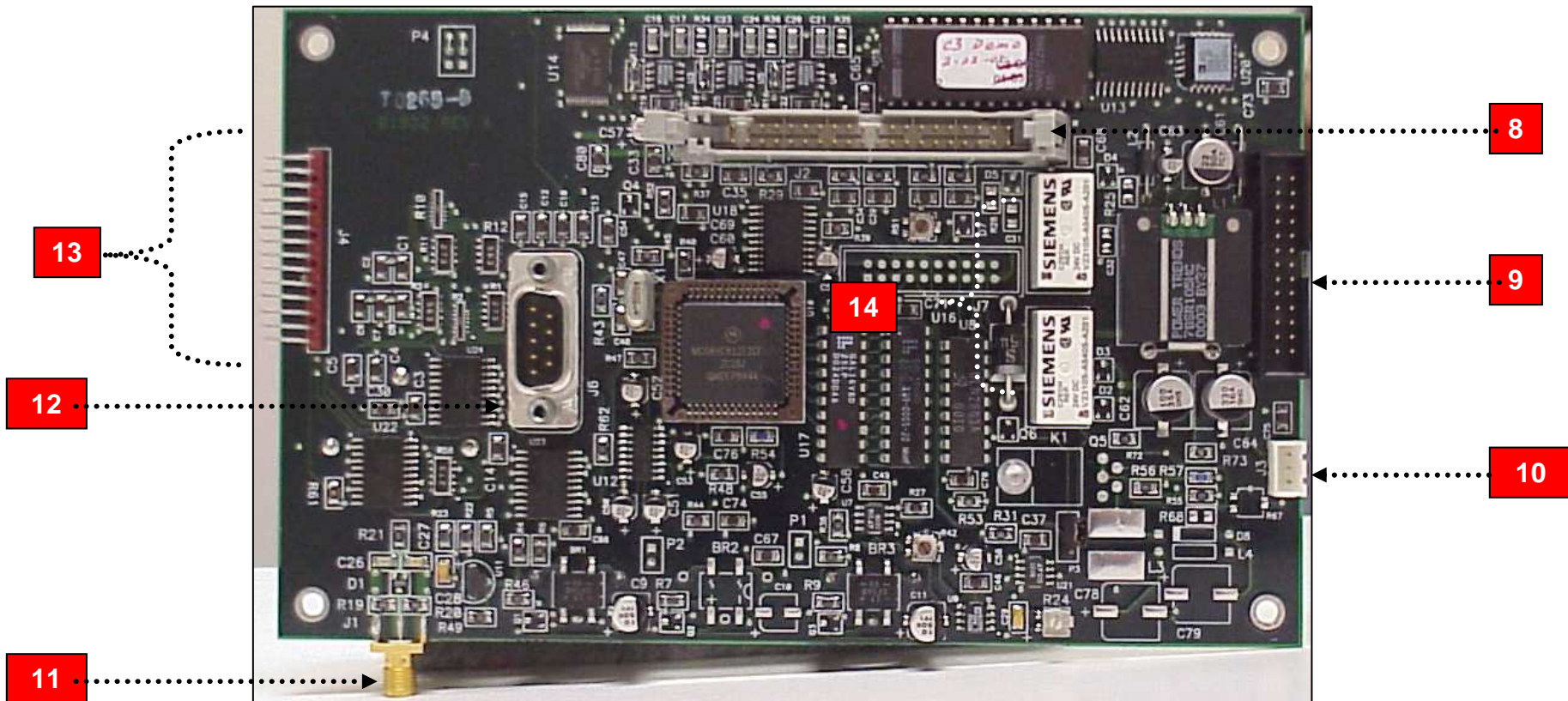

- 8- J2 40 Pin Connector (Most signal wires are terminated here!)**
- 9- J5 26 Pin Flat Cable (from front panel VFD)**
- 10- J3 5 VDC Power Supply to Vacuum Fluorescent Display**
- 11- J1 RF Cable Connection (Optional)**
- 12- J6 RS232 Cable (Menu Download port)**
- 13- J4 Keypad membrane cable**
- 14- Interlock Relays (Primary and Secondary)**